

POSjet[®] 1000

OPERATOR'S GUIDE

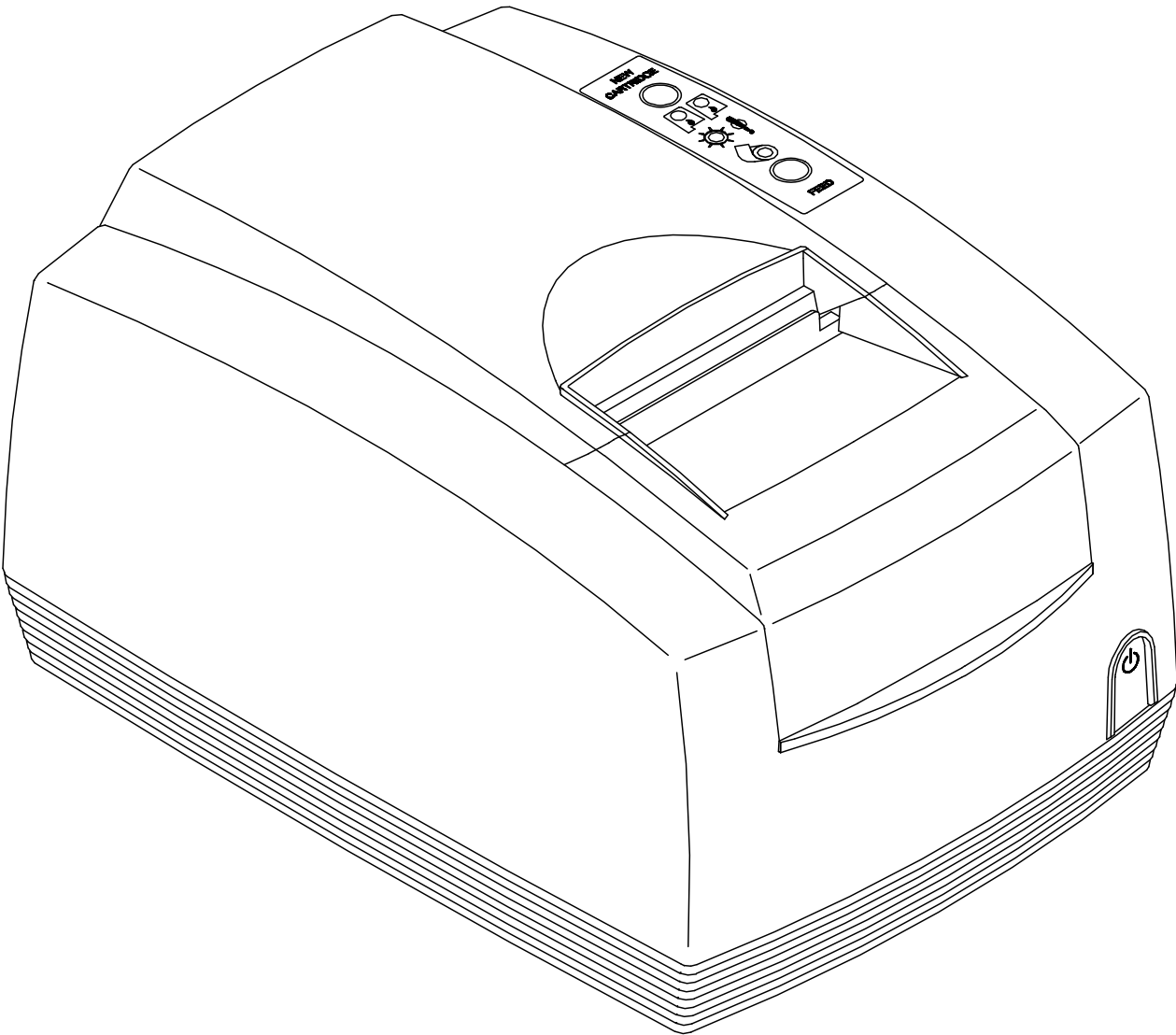

ithaca[®]
a product of TRANSACT

PN: 12-02396
Rev H
Nov-07

Change History

- Rev A Initial Release
- Rev B Corrected part numbers for parts list. Added Tech Support Info. Expanded all sections to make an Installation and a Operational section. Re-organized information. Updated Content. Updated Charts and Figures tables. Updated and expanded Index listings.
- Rev C New Keypad drawing. New Cable Restraint drawing. Corrected serial interface pin assignments. Included new Operational Troubleshooting keypad drawings. Added Environmental graph. General content updates and corrections.
- Rev D Updated resistration mark designations.
- Rev E Updated consumable parts to reflect Hi-quality paper roll additions.
- Rev F Updated disclaimer
- Rev G updated paper case p/n's, descriptions & qtys
- Rev H Added RoHS compliant power cord numbers in Appendix A

Product Information

Disclaimer

© 2003 TransAct Technologies, Inc. All rights reserved.

NOTICE TO ALL PERSONS RECEIVING THIS DOCUMENT:

The information in this document is subject to change without notice. No part of this document may be reproduced, stored or transmitted in any form or by any means, electronic or mechanical, for any purpose, without the express written permission of TransAct Technologies, Inc. ("TransAct"). This document is the property of and contains information that is both confidential and proprietary to TransAct. Recipient shall not disclose any portion of this document to any third party.

TRANSACT DOES NOT ASSUME ANY LIABILITY FOR DAMAGES INCURRED, DIRECTLY OR INDIRECTLY, FROM ANY ERRORS, OMISSIONS OR DISCREPANCIES IN THE INFORMATION CONTAINED IN THIS DOCUMENT.

Some of the product names mentioned herein are used for identification purposes only and may be trademarks and/or registered trademarks of their respective companies.

TransAct, PowerPocket, Magnetec, Insta-Load, POSjet, Ithaca, 50Plus and "Made to Order. Built to Last" are registered trademarks and BANKjet is a trademark of TransAct Technologies, Inc.

Copyright

© 2003 TransAct Technologies, Inc. All rights reserved.

Revision F, February 2003

Printed in USA.

Federal Communications Commission Radio Frequency Interference Statement

The *POSjet® 1000* Printer complies with the limits for a Class A computing device in accordance with the specifications in Part 15 of FCC rules. These regulations are designed to minimize radio frequency interference during installation; however, there is no guarantee that radio or television interference will not occur during any particular installation. Interference can be determined by turning the equipment off and on while the radio or television is on. If the printer causes interference to radio or television reception, try to correct the interference by one or more of the following measures:

1. Reorient the radio or television receiving antenna
2. Relocate the printer with respect to the receiver
3. Plug the printer and receiver into different circuits

If necessary, the user should consult their dealer or an experienced radio/television technician for additional suggestions. The user may find the following booklet prepared by the Federal Communications Commission helpful: *How to Identify and Resolve Radio/TV Interference Problems*. This booklet is available from the US Government Printing Office, Washington, DC 20402. Ask for stock number 004-000-00345-4.

Canadian Department of Communications Radio Interference Statement

The *POSjet® 1000* Printer does not exceed Class A limits for radio noise emissions from digital apparatus set out in the Radio Interference Regulations of the Canadian Department of Communications.

Regulatory Compliance

FCC Class A

ULc

CE Mark

UL 1950

TUV

TransAct Product Support

Monday through Friday, 8 A.M. to 5 P.M. (excluding holidays).

To obtain Technical Support, call: TransAct's Ithaca Facility at (607) 257-8901, or (877) 7ithaca.

Service Information

TransAct Technologies Incorporated has a full service organization to meet your printer service and repair requirements. If your printer needs service, please contact your authorized printer service center. If any problems still persist, you can directly contact the Ithaca Facility's Technical Support Department at (607) 257-8901 or (877) 7ithaca for a return authorization. International customers should contact your distributor for services. TransAct offers the following service programs to meet your needs.

Extended Warranty

Depot Repair

Maintenance Contract

Internet Support

Please have the following information at hand:

1. The Model Number and Serial Number.
2. A list of any other peripheral devices attached to the same port as the printer.
3. The application software, operating system, and network you are using.
4. A copy of your printer's Configuration Settings.
5. What happened and what you were doing when the problem occurred.
6. How you tried to solve the problem.

Warranty Information

TransAct's POSjet® 1000 Printers come with a standard 24-month warranty that commences upon shipment from factory, and covers parts and labor. An optional warranty, covering both parts and labor for an additional 12 months, may be purchased separately. Repairs are warranted for 90 days from the date of repair or for the balance of the original warranty period, whichever is greater.

Return Materials Authorization and Return Policies

If the technical support person determines that the printer should be serviced at our facility, and you want to return the printer for repair, a Returned Materials Authorization (RMA) number must be issued before returning the printer. Prepare the printer being returned for repair as follows:

1. Remove and discard ink cartridges.
2. Return all materials in the original packing. Packing items may be purchased from TransAct's Ithaca Facility.
3. Return only the accessories that a Support Technician asks you to include.
4. Write the RMA number clearly on the outside of the box.

Shipping Printers

Never ship a printer by any means with any ink cartridge(s) installed. Be sure to save the packing materials in the event that you need to send the printer in for servicing. TransAct Technologies is not responsible for damaged return items that are not packaged in original shipping material.

Where Can You Find More Information?

Our Internet Support and Sales Services

www.transact-tech.com

TransAct Technologies Incorporated maintains an internet web site with content devoted to supporting our products. Within the Support Services Section you can find documentation for the POSjet® 1000 Printer, including a current copy of the *Operator's Guide* and *Programmer's Guide*. The technical support page contains support information for our printers. The POSjet® 1000 Printer support pages offer the latest information. They include the current version of most manuals.

Programmer's Guide

The *Programmer's Guide* is available by down loading it from our web site and is intended for system engineers or integrators. It does not contain additional information on the Microline Emulation. It contains the information to integrate the POSjet® 1000 Printer with a point-of-sale terminal and to program the terminal to communicate with the printer in PcOS or ESC/POS mode.

The Programmer's Guide provides the following material:

- Start-up Information-Diagnostics and Fault Conditions
- Command Descriptions
- Character Fonts
- Printer Features
- Parallel and RS-232 Interface Information
- Communications and Buffers
- Command Code Reference Tables

In addition to the documentation listed above, a number of drivers are available that will support various environments.

Drivers and Utilities Available

POSjet® 1000 Drivers and Utilities can be downloaded from our web site, or call our Technical Support Department to request a Software Developer's Toolkit (CD-ROM).

Software Developer's Toolkit 100-02440

Drivers Available

Windows® 95/98/Me Print Driver and Documentation	98-9171
Windows® 2000/NT 4.0 Print Driver and Documentation	98-9172
OPOS Print Driver Manual	100-9730
OPOS Print Driver Disk 1	100-9731
OPOS Print Driver Disk 2	100-9732

Utilities Available

POSjet Image Converter Utility

POSjet Image Converter (PJColor) is a tool to help develop graphic images to use as logos and coupons on the printer. It will read and convert images to a format suitable for printing on the POSjet® 1000 printer. It will allow you to preview the image and adjust the colors prior to printing. It will also allow the images to be stored in the printer's User Store.

PJTerminal Utility

PJTerminal is a tool that has been developed to allow you to interactively send commands to and get responses from the printer.

Contacting TransAct's Ithaca Facility

Contact TransAct's Ithaca facility for information about the POSjet® 1000 Printer and how it works with your system. For information on International distribution, visit our web site at www.transact-tech.com. Contact the TransAct's Sales and Technical Support Departments at the following address and telephone or fax numbers.

Technical Support

Receive technical support, order documentation, request additional information, or send in a printer for service.

Sales

Order supplies, receive more product information, or order product brochures.

TransAct Technologies Incorporated

Ithaca Facility
20 Bomax Drive
Ithaca, NY 14850 USA

Telephone	(877) 7ithaca or (607) 257-8901
Main fax	(607) 257-8922
Sales fax	(607) 257-3868
Technical Support fax	(607) 257-3911
Web site	http://www.transact-tech.com

What is covered in this Operator's Guide?

This Operator's Guide is organized in two sections. The first section covers proper installation and setup procedures, and the second includes information on using the printer.

Section 1: Installation and Setup Information	
Unpacking the Printer Connecting the AC Power Cord Connecting the DC Power Cord Using the Cable Restraints Connecting the Communication Cable Connecting the Cash Drawer Paper Low Setup Loading New Ink Cartridges and Paper Rolls Confirming Configuration Settings Installation and Setup Troubleshooting Printer Specifications	Chapter 1: Step-by-Step Installation Instructions on page 1. Chapter 1 includes a five-step process that provides the required information to setup the POSjet® 1000 for the first time.
	Chapter 2: Installation and Setup Troubleshooting on page 12. Chapter 2 lists several potential problems that may be experienced during and after the installation process is completed. This information is listed by problem type and gives the possible cause and remedy for each listing.
	Chapter 3: POSjet® 1000 Specifications on page 13. Chapter 3 provides the specifications for the POSjet's installation and proper usage. Topics include interface requirements, operating conditions, power requirements, and print characteristics.
Section 2: Operational Information	
Using Keypad Controls Color-Ready Option and Ink Cartridge Usage Self-Test Mode Configuration Mode Connections and Communication Operational Troubleshooting Ordering Supplies Most Frequently Asked Questions	Chapter 4: Using Keypad Controls on page 26. Chapter 4 includes information on the POSjet's keypad buttons and indicator lights and explains how fault indicators work.
	Chapter 5: Color Ready Option and Ink Cartridge Usage on page 26. Chapter 5 explains the difference between one cartridge and two cartridge printing and provides information on how each printing option influences the configuration settings of the printer. Ink cartridge care and status are also covered, and several keypad displays show how the indicator lights represent cartridge status.
	Chapter 6: Self-Test Mode on page 36. Chapter 6 gives a basic overview of what self-test is and how to use it to test the functionality of your printer.
	Chapter 7: Configuration Mode on page 37. Chapter 7 gives an explanation of configuration mode and explains how the new cartridge button is used to change and save configuration settings.
	Chapter 8: Connections and Communication on page 38. Chapter 8 provides parallel and serial requirements, and also gives pin assignments. It also covers cash drawer driver interface specifics like the interface card and shunt positioning for the Star, Ithaca®, and Epson emulations.
	Chapter 9: Operational Troubleshooting on page 40. Chapter 9 lists troubleshooting procedures for the most frequently occurring problems that a user will experience while operating the POSjet® 1000.
	Appendix A: Ordering Supplies on page 43. Ordering supplies.
	Appendix B: Most Frequently Asked Questions on page 44. Most frequently asked questions.

Table 1 Where to find specific information

Table of Contents

Change History	i
Product Information	i
Disclaimer	i
Federal Communications Commission Radio Frequency Interference Statement	i
Canadian Department of Communications Radio Interference Statement	i
Regulatory Compliance	i
TransAct Product Support	ii
Service Information	ii
Warranty Information	ii
Return Materials Authorization and Return Policies	ii
Shipping Printers	ii
Where Can You Find More Information?	iii
Our Internet Support and Sales Services	iii
Programmer's Guide	iii
Drivers and Utilities Available	iii
Drivers Available	iii
Utilities Available	iii
Contacting TransAct's Ithaca Facility	iv
Technical Support	iv
Sales	iv
TransAct Technologies Incorporated	iv
What is covered in this Operator's Guide?	v
Table of Contents	vii
Figures	ix
Tables	ix
Section 1 Installation and Startup Information	1
Chapter 1: Step-by-Step Installation Instructions	1
Step 1: Unpack the Printer	2
Step 2: Connect Power and Communications	3
Connecting the AC Power Cord (with power supply)	3
Connecting the DC Power Cord (no power supply)	4
Using the Cable Restraints	4
Connecting the Communication Cable	5
Connecting the Cash Drawer	6
Step 3: Paper Low Setup	7
Adjusting the Paper-Low Sensor	7
Paper Low Adjustment Requirements	8
Step 4: Loading Ink Cartridges and Paper	9
Installing Ink Cartridges	9
Installing a New Paper Roll Using Insta-Load™	10
Step 5: Confirm Configuration Settings	11
Chapter 2: Installation and Setup Troubleshooting	12
Correcting Common Startup Problems	12
Chapter 3: POSjet® 1000 Specifications	13
Standard Features	13
Optional Features	13
Auto-cutter (Partial Cut Option)	13
Optional Printer Configurations	14
Supported Emulations	14
Dimensions	15
Reliability	16
AC Power Requirements	16
DC Power Requirements	16
Printing Specifications	17
Print Characteristics	20
Environmental Conditions	21
Relative Humidity	21
Media Specifications	22
HP Ink Cartridges	22
Receipt Paper (one-ply receipt)	22
Receipt Printing, Auto-cutter Position	23
Paper and Core Diameter	23
Hewlett-Packard Inkjet Cartridges	24
HP Ink Cartridge Specifications and Dimensions	24
Ink Cartridge Operating Conditions (maximum ratings)	24
Section 2 Operational Information	25
Chapter 4: Using Keypad Controls	26
Operating the Keypad	26
* Button	27

FEED Button.....	27
NEW CARTRIDGE Button	27
Quick Start Reference to using Keypad Buttons	28
Using the NEW CARTRIDGE Button in Self-Test Mode.....	29
Indicator Light Descriptions.....	29
Fault Indicators	30
Determining Ink Cartridge Status.....	31
Error Indicator Chart	32
Paper Low and Paper Out Sensing.....	32
Chapter 5: Color Ready Option and Ink Cartridge Usage	33
Overview of Color Ready Option.....	33
Color Ready Configuration	33
Care of Ink Cartridges.....	34
Determining Ink Cartridge Status.....	35
Chapter 6: Self-Test Mode	36
Placing the Printer In Self-Test Mode	36
Exiting Self-Test Mode	36
Self-Test Hints and Suggestions.....	36
Chapter 7: Configuration Mode	37
Changing Printer Configuration	37
Placing the Printer In Configuration Mode (Manual Configuration Mode)	37
Using the New Cartridge Button in Configuration Mode.....	37
Chapter 8: Connections and Communication	38
Parallel Interface.....	38
Parallel Pin Assignments.....	38
Serial Interface	38
Serial Pin Assignments.....	38
Cash Drawer Interface Description and Specifics	39
Cash Drawer Pin Assignments.....	39
Chapter 9: Operational Troubleshooting.....	40
Keypad Indicator Troubleshooting Chart	40
Serious Problems Indicator Warnings	40
Appendix A: Ordering Supplies	43
Ordering Supplies	43
Appendix B: Most Frequently Asked Questions.....	44

Figures

Figure 1 Unpacking Instructions 2

Figure 2 Connecting the AC Power Cord (with power supply) 3

Figure 3 Connecting the DC Power Cord (no power supply) 4

Figure 4 Connecting Serial Cable 5

Figure 5 Connecting Parallel Cable 5

Figure 6 Connecting Cash Drawer 6

Figure 7 Paper Low Setup (adjusting the sensor) 7

Figure 8 Installing Ink Cartridges 9

Figure 9 Installing New Paper Roll 10

Figure 10 Printer Dimensions 15

Figure 11 Draft 12 x 12 Font 18

Figure 12 Large 12 x 14 Font 18

Figure 13 NLQ 24 x 16 Font 19

Figure 14 Environmental Conditions:Typical Operating Range 21

Figure 15 Receipt Printable Area 23

Figure 16 Paper Roll and Paper Core Diameters 23

Figure 17 HP Ink Cartridge Specifications 24

Figure 18 Keypad Buttons and Indicator Lights 26

Figure 19 Cash Drawer Pin-outs 39

Tables

Table 1 Where to find specific information v

Table 2 Paper Low Setup 8

Table 3 Troubleshooting: Nothing Happens at Startup 12

Table 4 Troubleshooting: Printer Communications Failure 12

Table 5 Troubleshooting: Ink Cartridge Status Indicator Flashing 12

Table 6 POSjet Power Requirements 16

Table 7 Power Input Requirements Optional 24-volt DC Supplied from Host 16

Table 8 Character Specifications 17

Table 9 Print Speed Specifications 17

Table 10 Basic Cell Size for Draft, Large Draft, and NLQ Fonts 18

Table 11 POSjet Print Characteristics 20

Table 12 Ink Cartridge Maximum Operating Conditions 22

Table 13 Ink Cartridge Maximum Operating Conditions 24

Table 14 Using Buttons Quick Reference Table 28

Table 15 Keypad Indicators: Ink Cartridge Status 31

Table 16 Error Indicator Chart: General Problems 32

Table 17 Error Indicator Chart: Serious Problems 32

Table 18 Single Color Printer-Color Configuration Details 33

Table 19 Two Color Ready Operation-Color Configuration Details 33

Table 20 Two Color Operation-Color Configuration Details 34

Table 21 Keypad Indicators: Ink Cartridge Status 35

Table 22 How to Change Configuration Settings 37

Table 23 Parallel Interface Pin-outs 38

Table 24 Serial Interface Pin-outs 38

Table 25 Keypad Indicators: General Problems 40

Table 26 Keypad Indicators: Serious Problems 40

Table 27 Troubleshooting: Keypad Lights Will Not Work 41

Table 28 Troubleshooting: Printer Will Not Print (Error Light ON) 41

Table 29 Troubleshooting: Printer Will Not Print (Error Light OFF) 41

Table 30 Troubleshooting: Printer Prints With Missing Dots in Characters 42

Table 31 Troubleshooting: Printer Sounds Like It's Printing But Nothing Prints 42

Table 32 Troubleshooting: Printer Will Not Load or Feed Paper 42

Table 33 Paper Ordering Information 43

Table 34 Paper Ordering Information 43

Table 35 Ink Cartridge Ordering Information 43

Table 36 Cables Ordering Information 43

Table 37 Most Frequently Asked Questions 44

Section 1

Installation and Startup Information

Chapter 1: Step-by-Step Installation Instructions

By following the instructions in this section, the POSjet® 1000 will be ready to accept commands and successfully interface with your system in just a few minutes. Follow the steps below when setting up your printer.

- Step 1: Unpack the Printer pg. 2
- Step 2: Connect Power and Communications pg. 3
- Step 3: Paper Low Setup pg. 7
- Step 4: Loading Ink Cartridges and Paper pg. 9
- Step 5: Confirm Configuration Settings..... pg. 11
- Chapter 2: Installation and Setup Troubleshooting..... pg. 12
- Chapter 3: POSjet® 1000 Specifications..... pg. 13

Step 1: Unpack the Printer

Be sure to save the box and packing materials in case you need to send the printer in for service. Transact Technologies is not responsible for damaged return items that are not packaged in original shipping material. Refer to “Return Materials Authorization and Return Policies”, on page ii for information on what to do if you have to return your printer for repair.

1. Open the box and remove the printer and all items. Check to make sure that all items are present.
 - POSjet® 1000 Printer
 - Ink Cartridge(s)
 - Paper Roll (located under the rear paper cover)
 - PowerPocket™ Power Supply located in cabinetry base (*optional*)
 - AC Power Cord (*optional*)
2. Separate the printer from the packing material. Reverse steps when repacking for return shipment.
3. Check the printer for any signs of damage. If the printer or any parts are damaged, report it to your supplier and shipper immediately.

Be sure to save the box and packing materials in case you need to send the printer in for service. (You will not need to repack the supplies).

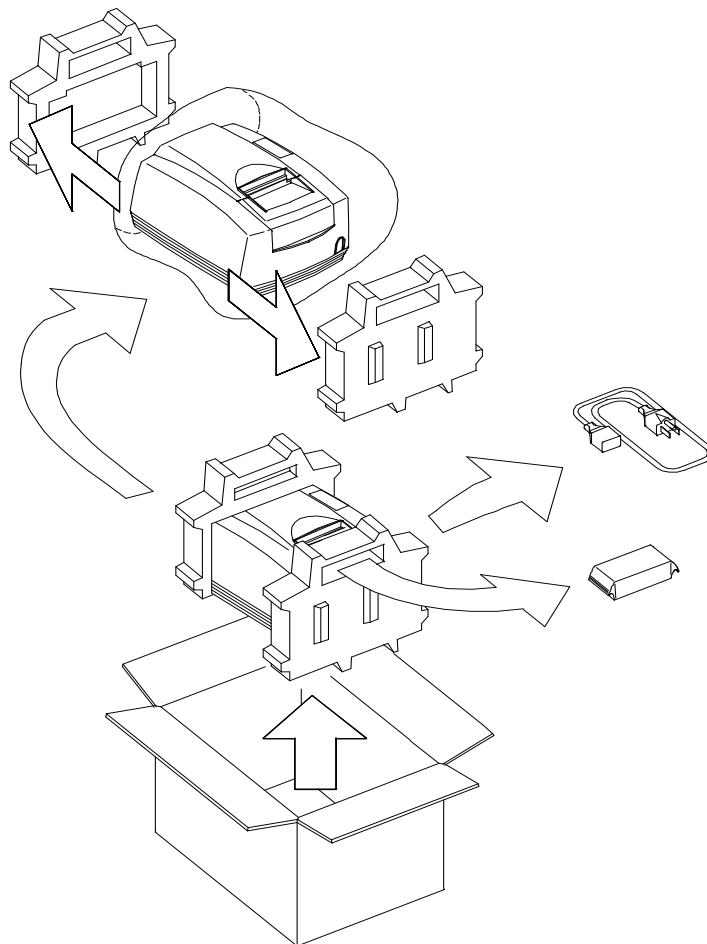

Figure 1 Unpacking Instructions

Step 2: Connect Power and Communications

Connecting the AC Power Cord (with power supply)

1. Orientate the printer upside-down and find the POSjet's power supply's power socket.
2. Locate the power cord and connect it to the power socket (power supply) located on the back of the printer and to an external AC power outlet. The socket-outlet shall be installed near the equipment and shall be easily accessible.
3. Route the power cord through the cable restraints. Refer to the drawing below to see how to route cord. Failure to use the cable restraints may result in the printer becoming accidentally unplugged during operation.
4. Turn on the printer by pressing the * button. The printer takes 1.5 seconds to begin operation.

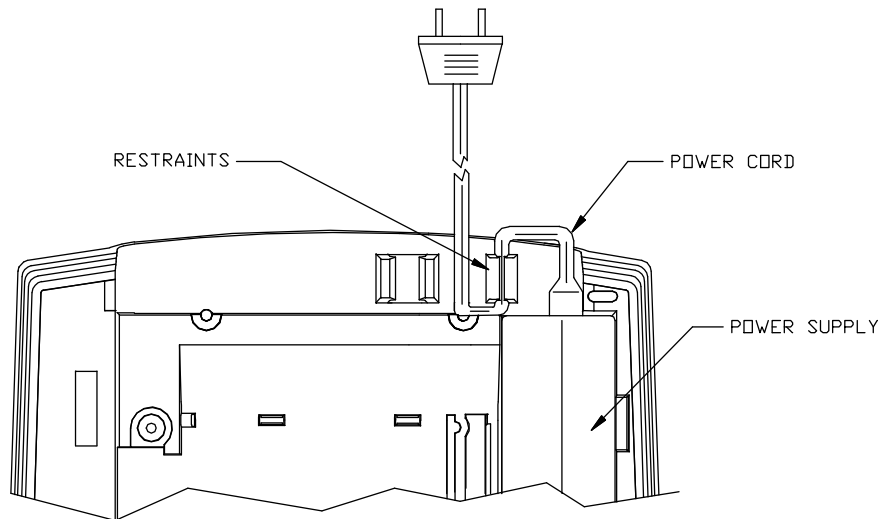

Figure 2 Connecting the AC Power Cord (with power supply)

Connecting the DC Power Cord (no power supply)

1. Orientate the printer upside-down and find the DC power socket on the side of the interface card (PCB).
2. Locate the DC power cord and connect it to the interface card's power socket, then route the cord through the cable restraint. Failure to use the cable restraints may result in the printer becoming accidentally unplugged during operation.
3. Turn on the printer. Press the * button. The printer takes 1.5 seconds to begin operation.

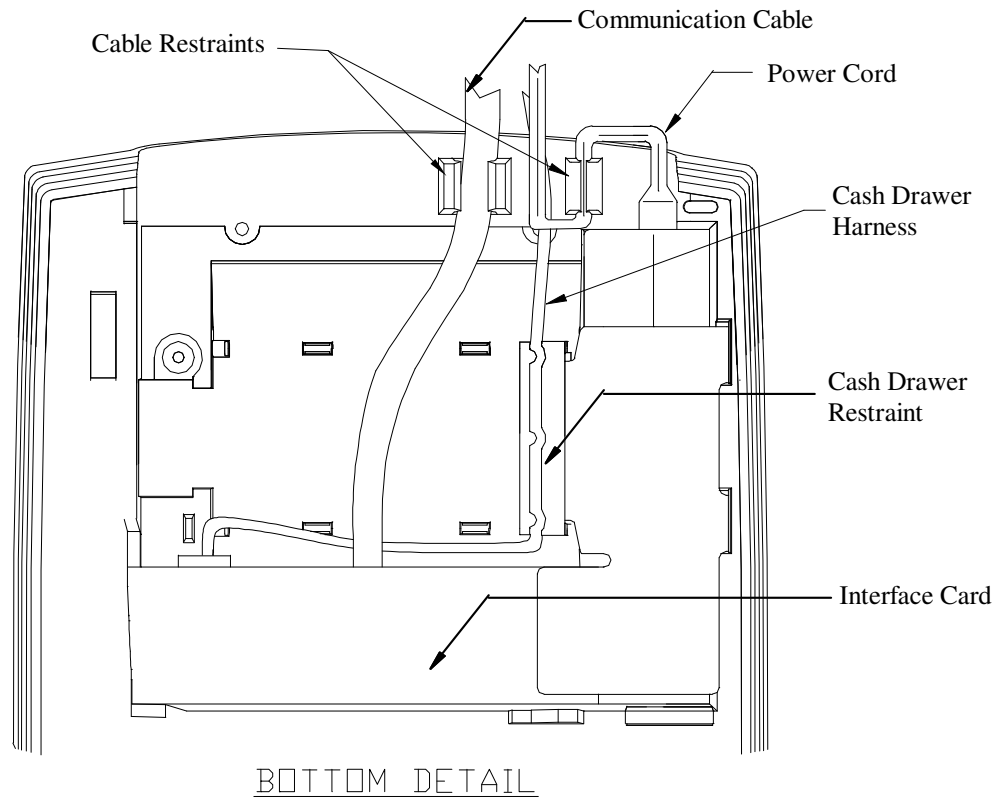

Figure 3 Connecting the DC Power Cord (no power supply)

Using the Cable Restraints

Cable restraints have been developed to protect against accidental unplugging of the printer while it is in use. Be sure to properly route the communications cable using the restraints provided on the back of the printer.

1. Orientate the printer upside-down and locate the cash drawer restraint. The cash drawer restraint is offset from the middle of the cabinetry base.
2. Plug the cash drawer harness into the connector on the printer's interface card.
3. Route the harness through the cash drawer cable restraint, then position it between the two remaining cable restraints and connect it to your system.

Connecting the Communication Cable

Depending on the interface your system uses, either connect the serial or parallel communication cable to the appropriate connector on the back of the printer. Cables are provided by your dealer or system installer. If cables are unavailable, see “Contacting TransAct’s Ithaca Facility”, on page iv.

Connecting the Serial Cable to the Printer

1. Use the * button to turn off the printer. Also turn off your host system or personal computer.
2. Connect the 9/25-pin serial interface cable to the connector located on the back of the printer. Refer to “Serial Interface”, on page 38 for information on the serial cable requirements.
3. Tighten the two mounting screws on each side of the cable connector.
4. Route the communication cable through the cable restraint and connect the cable to your host system. Refer to the drawing for “Using the Cable Restraints”, on page 4.

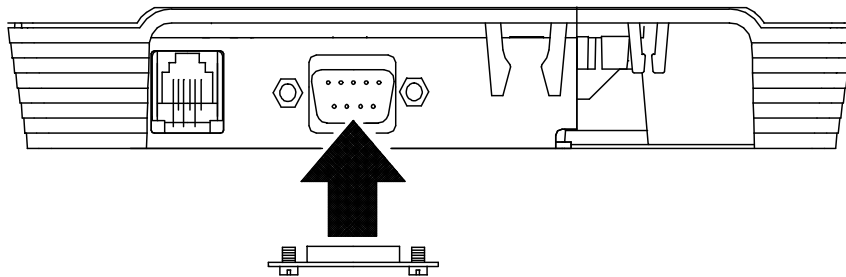

Figure 4 Connecting Serial Cable

Connecting the Parallel Cable to the Printer

1. Use the * button to turn off the printer and host system or personal computer.
2. Connect the 25/36-pin parallel interface cable to the connector located on the back of the printer. Refer to “Parallel Interface”, on page 38 for more information on parallel connection requirements.
3. Tighten the two mounting screws on each side of the cable connector (25 pin only). Or, engage the locking clips (36 pin only).
4. Route the communication cable through the cable restraint and connect to your host system. Refer to the drawing for “Using the Cable Restraints”, on page 4.

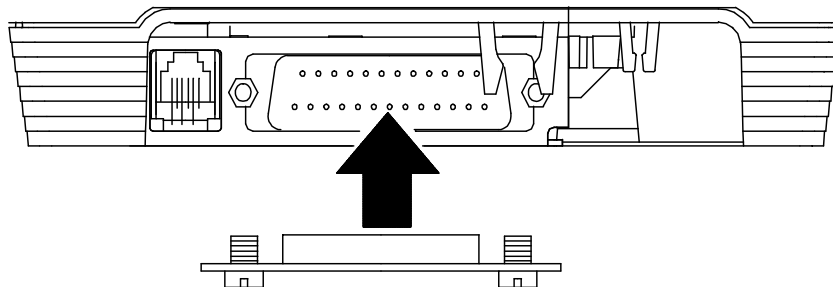
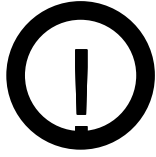

Figure 5 Connecting Parallel Cable

Connecting the Cash Drawer



Check the CAUTION label on the bottom of printer. This label indicates the cash drawer configuration setting that shipped with the printer. There will be either an Ithaca, Star, or Epson compatability sticker on your printer. Verify that the label's configuration matches the cash drawer in your application.

The POSjet® 1000 Printer supports dual cash drawers with status.

The Cash Drawer can be configured for one of three settings. The interface card has a 14-pin header with a 10-pin shunt installed on it. The shunt position defines the configuration of the cash drawer. Refer to the markups on the board when determining where the shunt should be installed to work in the three different configurations. Refer to “Cash Drawer Interface Description and Specifics”, on page 39 for information on how to install the cash drawer.

Connecting Cash Drawer Cable to the Printer

1. Use the * button to turn the printer off.
2. Orientate the printer so you are looking at the rear underside of the unit and locate the small cash drawer connector to the left of the communication connector.
3. Connect the cash drawer cable to the connector located on the back of the printer, making sure that the cash drawer cable snaps into place.

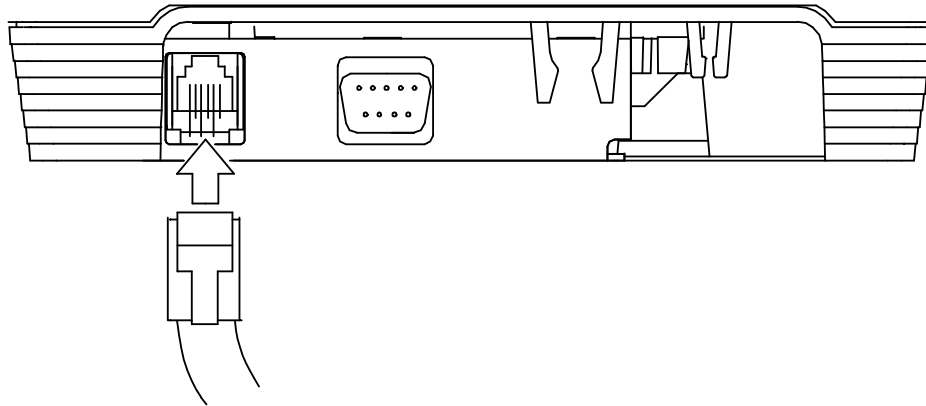

Figure 6 Connecting Cash Drawer

Step 3: Paper Low Setup

All printers ship with a factory default, mid-position setting that can be adjusted up or down with 1 to 3 full turns of the adjustment screw. The amount of paper remaining after paper low detection is dependent on this adjustment. Generally, in most cases the paper low setup does not need to be changed from the factory setting.

Adjusting the Paper-Low Sensor

1. Open the rear paper cover and locate the paper low adjustment access hole.
2. Refer to Table 2 on the following page for specific adjustment settings.
3. Turn screw to control the amount of paper that is remaining after paper low has occurred.

CAUTION: When the sensor touches the plastic of the cabinetry base (lower limit only), the sensor should not be adjusted any further. Over adjustment will cause stress in the sensor material and will decrease its longevity.

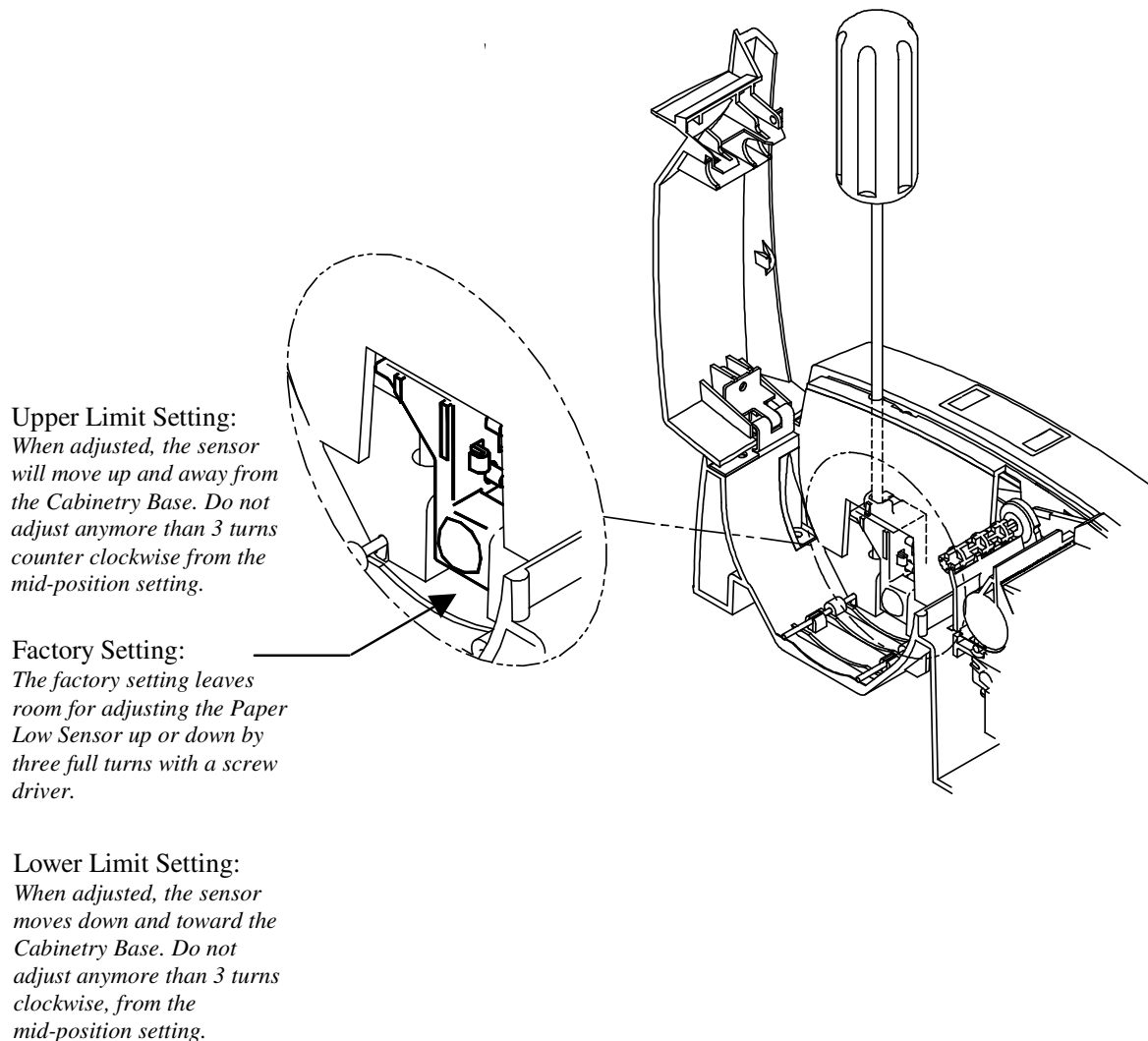

Figure 7 Paper Low Setup (adjusting the sensor)

Paper Low Adjustment Requirements

Use the following table to decide how much paper you want to remain after paper low sensing has occurred. TransAct's expected results are based on paper and paper roll with these specifications.

Paper Low Adjustment Settings	Approximate Paper Remaining (in feet)	Paper Roll Diameter
UPPER LIMIT: 3 turns (counter clockwise)	24'	1.420" (36mm)
2 turns (counter clockwise)	22'	1.375" (34.9mm)
1 turns (counter clockwise)	16'	1.250" (31.7mm)
FACTORY SETTING	12'	1.175" (29.8mm)
1 turn (<i>clockwise</i>)	7'	1.050" (26.6mm)
2 turns (<i>clockwise</i>)	3.5'	.950" (24.1mm)
LOW LIMIT: 3 turns (clockwise)	1.25'	.885" (22.4mm)

Table 2 Paper Low Setup

- Refer to "Chapter 3: POSjet® 1000 Specifications", on page 13 for paper measurements.
- Refer to "Paper and Core Diameter", on page 23 for core dimensions.
- Always check that the core is aligned with the right edge of the paper roll, as installed.

Step 4: Loading Ink Cartridges and Paper

NOTE: When installing new ink cartridges and a new paper roll for the first time, you may leave both covers open until you have installed the ink cartridges, and the paper roll.

Installing Ink Cartridges

The printer should be turned ON by using the * Button before you install ink cartridges. Confirm that the printer is ON by checking that the power indicator light is activated. Refer to “Chapter 4: Using Keypad Controls”, on page 26 for information on the power indicator light.

Caution: Do not touch ink cartridge’s metallic connector surface with your fingers. Doing so will contaminate the connector and produce bad print quality.

1. Open the front cover of printer (Opening front cover automatically opens rear paper cover.)
(NOTE: If paper is present, ensure that receipt is torn off prior to opening front cover.)
2. Pull down blue cartridge latch/latches
3. Remove new ink cartridge from sealed pouch.
(Hold cartridge by round tab to avoid contamination.)
4. Remove mylar tape from face of new ink cartridge.
5. Place new ink cartridge(s) into carriage. Hold round tab to ensure clean installation. Refer to the drawings below to see how to install the ink cartridges into carriage. Refer to “Changing Printer Configuration” on page 37 to confirm that your printer has the proper configuration settings.
6. Close blue latch/latches.
7. Press the NEW CARTRIDGE Button. Doing this initializes the ink status on the newly inserted ink cartridges.

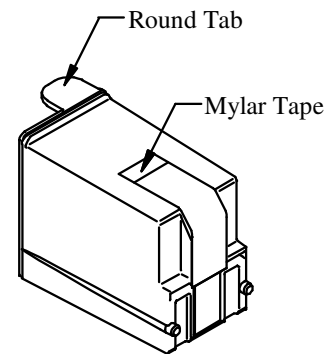
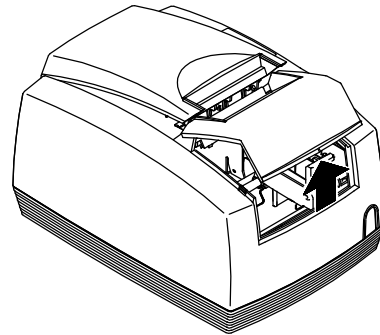

Note: If you are installing the printer, an ink cartridge or cartridges can be found in the pouch that shipped with your printer.

Open Blue Latch

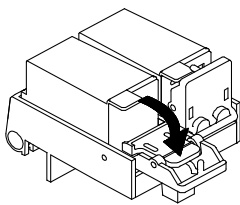

Remove Old Cartridges

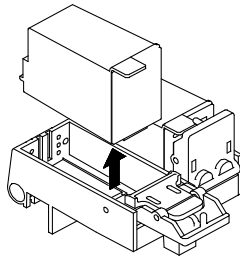

Replace with new cartridge(s)

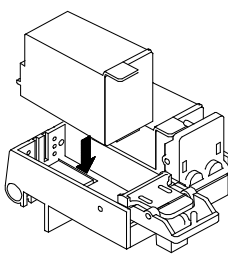

Close Blue Latch

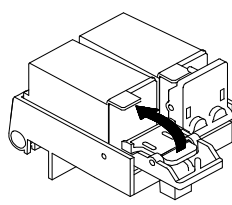
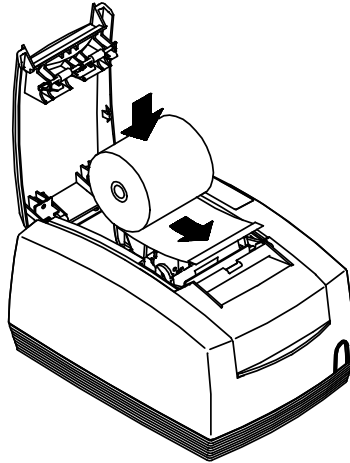

Figure 8 Installing Ink Cartridges

Installing a New Paper Roll Using Insta-Load™

Before you attempt to load the paper roll, make sure that the printer is plugged in and that the printer is turned ON. **!IMPORTANT!:** Paper cannot be loaded for the first time without first installing ink cartridge(s). *If this is a new installation, a small receipt roll is supplied with the printer.*

1. Open printer's rear paper cover. (First time installers will already have the cover open from installing ink cartridges.)



2. Insert the paper roll so that the paper unwinds from the bottom and rests on the top of the front cover.
3. Make sure paper is to the top front edge of the front cover. This is done to give the printer enough room to complete the automatic loading process and prepare for operation.

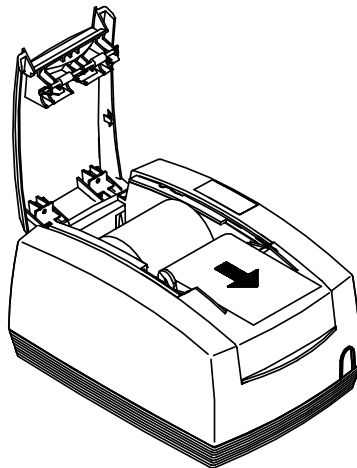

4. Close the rear paper cover. The printer will automatically load the paper through the feeding mechanism. If the paper does not feed, repeat the steps.

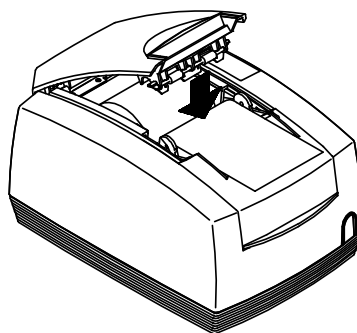

Figure 9 Installing New Paper Roll

Step 5: Confirm Configuration Settings

A configuration receipt was included with your printer when it was shipped from our factory and can be found in the paper roll compartment of the printer. This configuration receipt shows how your printer has been configured, and also contains other factory default settings that will be helpful when determining whether or not your system will integrate properly or whether you need to adjust your settings. Refer to “Chapter 7: Configuration Mode”, on page 37 for information on adjusting your POSjet’s settings to meet your system requirements.

Make sure these configuration parameters are compatible with your system

Parallel Printers

Emulation

Carriage Return Options

Serial Printers

Emulation

RS-232 Serial Interface (baud rate)

Carriage Return Options

At this point, your printer should be completely installed and ready to accept commands. Refer to additional information about setup troubleshooting, printer specifications, and operational information as needed.

Chapter 2: Installation and Setup Troubleshooting

Correcting Common Startup Problems

This troubleshooting section provides solutions to problems that may occur with your printer during installation. The following items are a list of possible problem areas. These categories have been established to assist you with preliminary information. For more in-depth troubleshooting information, refer to our Programmer's Guide available from our web site or call our Technical Support Specialists.

Check to see if the following items have been installed and connected properly to your printer.

1. Are both covers fully closed?
2. Are the power cord and all communication cables plugged in correctly?
3. Are the ink cartridges installed properly?
4. Have you completed the printer self-test?

Printer Does Not Turn ON	
Possible Cause	Remedy
Printer is OFF	Press and release the * Button
No AC Power	Confirm that AC power is available, and that the power cord is fully seated in the power supply's power socket.
No DC Power	Check connection of power supply output cable to the Interface Card.
Defective Interface Card	Check Interface Card for damage. Replace if needed.

Table 3 Troubleshooting: Nothing Happens at Startup

Printer Will Not Communicate (prints illegible receipts)	
Possible Cause	Remedy
Incorrect Cable Configuration	Turn printer OFF and reconnect communication cables.
Incorrect Printer Configuration	Compare configuration settings with application requirements. Use Self-Test to print out printer's configuration receipt, or compare to the configuration receipt that shipped with your printer.
Incorrect Cash Drawer Settings	Confirm that the sticker on the bottom of your printer matches the application system requirements. The setting should be one of three: Ithaca, Epson, Star. See "Connecting the Cash Drawer", on page 6.
Defective Interface Card	Check Interface Card for damage. Replace if needed.

Table 4 Troubleshooting: Printer Communications Failure

Ink Cartridge Status Indicator Flashing/ Printer will not Operate	
Possible Cause	Remedy
Cartridges(s) Not Installed	Ensure that the ink cartridge(s) are properly installed and the blue latch(es) are closed properly. If the printer is configured for two cartridges, both must be present. See "Installing Ink Cartridges", on page 9.
Poor Cartridge Installation	Remove ink cartridge(s) and re-install. Make sure the blue latches are closed properly. See "Installing Ink Cartridges", on page 9.

Table 5 Troubleshooting: Ink Cartridge Status Indicator Flashing

Chapter 3: POSjet® 1000 Specifications

Standard Features

The following features are common to the entire POSjet® 1000 family of printers.

- Up to 12 lines per second at 10 characters per line inches per second paper slew speed
- 2.5-inch print zone
- One color printing
- Paper Out Sensing
- Latch-in ink cartridge
- Dual cash drawer drivers with status (**Single Modular**)
- Centronics Parallel or Serial RS-232C Interface
- Configurable receiver buffer
- Custom logo graphic print buffer in nonvolatile memory
- Insta-Load™ paper loading capability
- PowerPocket™ (**External power supply that can be housed inside printer**)
- Self diagnostics
- Set up and configuration utility program
- Characters per inch (dpi) selections of 13, 14.8, and 17.3
- Three print fonts - Draft, Large Draft, and Near Letter Quality (**NLQ**)
- Selectable printing features of bold, italic, size scaling and/or rotated (**four 90 rotations**)

Optional Features

The optional features either replace a standard feature or enhance the operation of the printer. All optional features are installed at the factory and must be selected when the printer is ordered. The POSjet™1000 printer is available with a two cartridge carriage but without the second cartridge installed. This printer is termed Two Color Ready. It is configured as Black and no second cartridge and prints as a single cartridge printer would. When the printer has the second cartridge installed, it should be reconfigured for Two Color printing. This can be done through software, or with manual configuration.

- Two color printing (**black and 1 color**)
- Auto Cutter: Partial cut
- Adjustable Paper Low Sensor
- Extended Maintenance Plan (*call for details*)
- Auto-cutter (Partial Cut Option)
- A receipt auto-cutter is an optional feature with all POSjet™1000 Printers.

Auto-cutter (Partial Cut Option)

A receipt auto-cutter is an optional feature with all POSjet® 1000 Printers.

Cutter type	Guillotine
Paper roll width	3.0" ± .02" (76mm ± .5mm)
Media thickness range	0.003" to 0.004" (0.076 to 0.10 mm)
Cut to line of print	1.06" (26.92 mm)
Cutter life	1,000,000 cuts

Paper Out

A receipt paper out sensor is provided as a standard feature. It senses when there is approximately one inches of paper left on the paper roll.

Paper Low

A receipt paper-low sensor is provided as an optional feature. An operator-adjustable paper-low assembly allows the printer to sense when the paper roll is between 1.42" and 0.885" (36.1mm and 22.5mm) in diameter. It is adjustable to compensate for various paper core dimensions.

Optional Printer Configurations

Color Configuration

All POSjet™1000 optional features are installed at the factory and must be selected when the printer is ordered. The majority of factory options do not need the user to perform any additional setup steps. However, if the Two Color Ready optional setup is ordered, users will be required to adhere to specific operational procedures. See page “Color Ready Configuration” on page 33 for specific configuration requirements.

Single Color Setup

The Single Color printer setup is a factory built option. It is configured to handle a single ink cartridge and cannot be field upgraded for Two Color operation. When using the POSjet with a single cartridge setup the left ink carriage should contain a single BLACK cartridge, or a single color ink cartridge.

Two Color Ready Setup

The Two Color Ready setup allows the POSjet to operate as a Single Color printer with the option of reconfiguring the printer for Two Color (multiple color) printing. This reconfiguration can be done at anytime by TransAct or any one of our certified service technicians.

Two Color Setup

Two Color Operation setup allows the POSjet to operate as a Two Color printer. Two Color Setup uses a black ink cartridge in the left carriage socket, and a color ink cartridge in the right carriage socket.

Supported Emulations

Standard Emulation

The standard control codes for the POSjet™1000 Printer are extensions and subsets of the PcOS IBM emulation provided on other Ithaca® products. In some cases, an application designed for a Series 50 Printer with IBM code sets will function with a POSjet™1000 Printer.

IPCL Codes

Ithaca® Printer Control Language (IPCL) codes are part of PcOS and designed to control a printer without using control characters (i.e. characters less than 20H). Only the standard PcOS emulation supports IPCL. In rare cases, an IPCL code will interfere with the text that is to be printed. The IPCL translator is disabled by [ESC] y <4>.

EPOS Emulation

ESC/POS 1 is referred to here as EPOS. The POSjet™1000 Printer supports two Epson emulations. One emulation is for the TM200, and the other is a general EPOS emulation that has extensions that do not match any Epson printer. The TM200 emulation is designed to allow POSjet™1000 Printers to be used with applications that are designed for Seiko Epson TM200 printers. The EPOS emulation is an extension of the TM200 emulation that removes some of the limitations imposed by the TM200 and allows fuller use of the POSjet™1000 features. It is intended that the standard Ithaca® PcOS emulation be used for new applications. Not all features of POSjet™1000 Printers are supported by EPOS. Specifically, the ability to print color horizontal graphics is not supported.

Citizen 3500 Emulation¹

The POSjet® 1000 Printer supports Citizen emulation modes.

Star Emulation²

The POSjet® 1000 Printer supports Star emulation modes.

Ithaca® Microline Emulation³

The POSjet® 1000 printer supports several Microline Emulations. These emulation allow the printer to replace some older M50 printers with Microline commands. This emulation is not documented within this manual. Refer to our Microline Emulation Programmer's Guide (12-03244) for more information.

¹ Not all versions of the POSjet® 1000 Printer support the Citizen Emulation.

² Not all versions of the POSjet® 1000 Printer support the Star Emulation.

³ Not all versions of the POSjet® 1000 Printer support the Citizen Emulation.

Dimensions

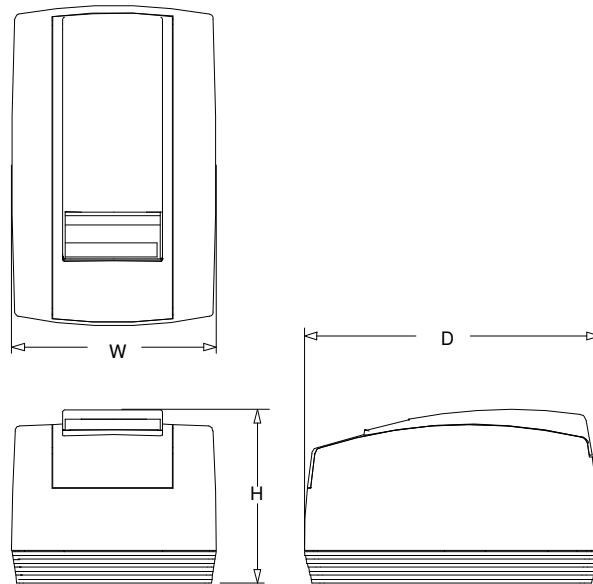

Figure 10 Printer Dimensions

	Width	Depth	Height
Without Knife	6.75" (171.45mm)	9.75" (247.65mm)	5.34" (135.64mm)
With Knife	6.75" (171.45mm)	9.75" (247.65mm)	5.81" (147.57mm)
Weight	6lbs. (2.7kg)		
Interface			
Serial RS-232C	Bi-directional-transmit/receive/ground (9-pin d-shell or 25-pin d-shell)		
Parallel IEEE1284	Bi-directional-transmit/receive/ground (25-pin d-shell or 36-pin Centronics)		
Printer			
Model	POSjet® 1000		
Printing Method	Thermal Inkjet		
Speed	12 lps at 10 characters per line		
Paper Dimensions			
Paper width:	3.0" ± .02" (76mm ± .5mm)		
Diameter:	4.0" max (101.6mm max)		
Thickness:	.003" - .004" (.07mm - .1mm)		
Nozzle Arrangement:	12 pins in line		
Print Zones:	Non-Contact, 1/8 inch		
Resolution:	96 Dots/Inch		
Text Firing Speed:	3000 Dots/Sec.		

Reliability

Mean time between failures: (without cartridge)	30,000 hours
Average cartridge life (Average 16 dots/character)	6.0 million characters
Autocutter option (partial cut)	1 million cuts
Mean time to repair	15 minutes

Printer in full operation. All data is based on Ithaca® standard test conditions simulating a normal retail operating environment. All cartridge information based on HP test data.

AC Power Requirements

The POSjet® 1000 is designed to be AC self-powered in domestic and international markets. The printer is equipped with a universal input power supply that is designed to operate worldwide without modification.

Supply Voltage Rating (VAC)	Supply Voltage Range (VAC)	Frequency (Hz)	Rated Power (watts)	Current Idle (amps)	Current Printing (amps)
100 - 240	90 - 264	47 - 63	25	0.08 @ 120VAC 0.04 @ 240VAC	.435 @ 100 VAC .281 @ 240 VAC

Table 6 POSjet Power Requirements

DC Power Requirements

Optionally, the POSjet® 1000 Printer can be operated with an external 24-volt DC power supply.

Supply Voltage Rating (VDC)	Supply Voltage Range (VDC)	Frequency (Hz)	Power (watts)	Idle Current (amps)	Current (amps)
24-5+10%	22.8 -26.4 ⁴	DC	25W Avg. (Printing)	0.125	2.0 (Cash Drawer Fire) 1.0 (Printing)

Table 7 Power Input Requirements Optional 24-volt DC Supplied from Host

⁴ For DC powered printers, the cash drawer is supplied directly from the DC input supply. The cash drawer requirements may effect the allowable range of voltages.

Printing Specifications

Printing method	Thermal ink jet
Cartridge arrangement	12 nozzle
Print dot diameter	0.012" (0.34 mm)
Print dot pitch	0.0096" (0.244 mm)
Printing directions	Bidirectional, logic seeking
Print zone (maximum)	2.5" (63.5 mm)

Characters per second Refer to Table 1

Characters per line Refer to Table 1

Characters per inch Refer to Table 1

Print Pitch Capability (Characters per Inch)				Max Characters/Line (2.5-inch Print Zone)			Approximate Characters per Second ⁵
Font	Half Wide (Max CPI)	Single-wide (Max CPI)	Double-wide	Max	Typ	Dbi-wide	
NLQ	Not Available	13.0	6.5	32	32	16	100
Large Draft	29.72	14.86	7.43	74	37	18	315
Small Draft	29.72	17.3	8.67	74	43	21	360

Table 8 Character Specifications

Characters per Line	Minimum Lines per Second ⁶
10	12
20	10
30	8
40	6

Table 9 Print Speed Specifications

⁵ The value is based on a single full 2.5" print line printing single width, small draft font. Line feed time is not included.

⁶ Print speed is calculated with the 12 x 12 single wide font at 17.3 cpi and 8 lpi spacing. If head maintenance needs to be done, the print speed will be less.

Character Generation

Standard Print

The three resident fonts in the printer are Draft, Large Draft, and Near Letter Quality (NLQ). The cell size for each is different. In addition, the Small and Large draft fonts can be printed in Double, Single and Half wide versions. All the width variations are based on the single width and use mathematical algorithms to convert them to different widths. The following discussion is based on the basic single width character.

Character Cell	Draft	Large Draft	NLQ
Horizontal	12	14	16
Vertical	12	12	24

Table 10 Basic Cell Size for Draft, Large Draft, and NLQ Fonts

Draft Font

The draft font is defined in the 12 x 12 cell to use 6 full-columns and 5 half-columns horizontally. In general, most characters are only nine dots wide; however, to provide readable international characters, the minimum cell size is kept at 12. The minimum cell size provides at least 1 half-column between any character.

The vertical format never uses the top dot, and the bottom 2 dots are used for character decenders and underline. The draft font provides the most print per line and the most efficient use of ink per character.

```

01 .....
02 ....0.0....
03 ...0...0...
04 ..0.....0...
05 .0.....0..
06 .0.0.0.0.0..
07 .0.....0..
08 .0.....0..
09 .0.....0..
10 .0.....0..
11 .....
12 .....

```

Figure 11 Draft 12 x 12 Font

Large Draft Font

The large draft font is defined in the 12 x 14 cell to use 7 full, and 6 half-columns horizontally, which provides at least 1 half-column between any character.

The vertical format uses the first 10 rows for the characters and the bottom 2 for character decenders and underline. The large draft font is larger than the draft font and is more readable. It, however, provides fewer characters per line and uses more ink per character.

```

01 .....0.0.....
02 ....0...0.....
03 ...0...0.....
04 ...0.....0...
05 ..0.....0...
06 .0.....0...
07 .0.0.0.0.0..
08 .0.....0..
09 0.....0..
10 0.....0..
11 .....
12 .....

```

Figure 12 Large 12 x 14 Font

Near Letter Quality (NLQ) Font

The near letter quality font is defined in the 24 x 16 cell that is printed in 2 passes. Horizontally, 15 dots are typically used, providing at least 1 half-column between any two characters.

The vertical format uses rows 4 - 19 for the basic character, rows 1 - 3 for accents, and rows 20 - 24 for descenders and underlines. Because NLQ font makes two passes, the vertical size is slightly larger than large draft font. Vertical resolution is doubled.

NLQ font is easily readable and has a higher contrast than the draft or large draft fonts. It, however, provides fewer characters per line and uses more ink per character than either draft font.

```

01 .....
02 .....
03 .....
04 .....0.....
05 .....0.....
06 .....0.0.....
07 .....0..0.....
08 .....0..0.....
09 .....0....0....
10 .....0....0....
11 .....0....0....
12 .....0....0....
13 .....0....0....
14 ..0000000000...
15 ..0.....0...
16 ..0.....0...
17 ..0.....0...
18 ..0.....0...
19 0000.....0000.
20 .....
21 .....
22 .....
23 .....
24 .....

```

Figure 13 NLQ 24 x 16 Font

In non-Ithaca® emulation modes, only the draft and large draft fonts are available. They provide a close approximation to the Epson 9 x 9 and 7 x 9 formats available in the TM200 model printer.

Rotated Print

To provide printing flexibility, rotated print is available. Rotated print mode rotates the print in any of three 90° orientations. In 90° and 270° rotated mode, the print data is first buffered by the printer, processed (rotated), and then printed. Buffering the data delays the print process as it takes some time to process the data before it is printed. In 180° mode, the print is simply inverted. Rotated print is not available for NLQ font or when the printer is in Epson mode.

Print Characteristics

The POSjet® 1000 prints characters in a variety of pitches as shown in the following table. Each pitch can be printed in a variety of styles affecting the appearance of the characters and the speed of the printer. For information about programming the printer to use a particular pitch or style, refer to the Programmer's Guide. You can order the Programmer's Guide from TransAct's Ithaca facility, or download it directly from the "Support Services" section of our web site.

Pitch (Characters per Inch)	Max Characters per Line	Characters per Second
8 CPI	18	220
10 CPI	24	275
12 CPI	28	330
15 CPI	36	340
17.1(Condensed)	41	340
20 (Super Condensed)	48	340
23 (Super Condensed)	57	340
5 (Double-wide)	12	175
6 (Double-wide)	14	175
7.5 (Double-wide)	18	175
8.5 (Condensed Double-wide)	20	175
10 (Condensed, Double-wide)	24	175
12 (Super Condensed, Double-wide)	28	175

Table 11 POSjet Print Characteristics

Environmental Conditions

The POSjet® 1000 is designed to be placed on point-of-sale terminals, counter tops, or any other flat, stable surface that can support the weight of the printer (about 6 lbs. or 2.7 kg). Be aware that the environmental conditions of the location where you place the printer will have an effect on the printer's performance and longevity. The printer will run its best when stored and operated in an environment that meets the following temperature and humidity conditions.

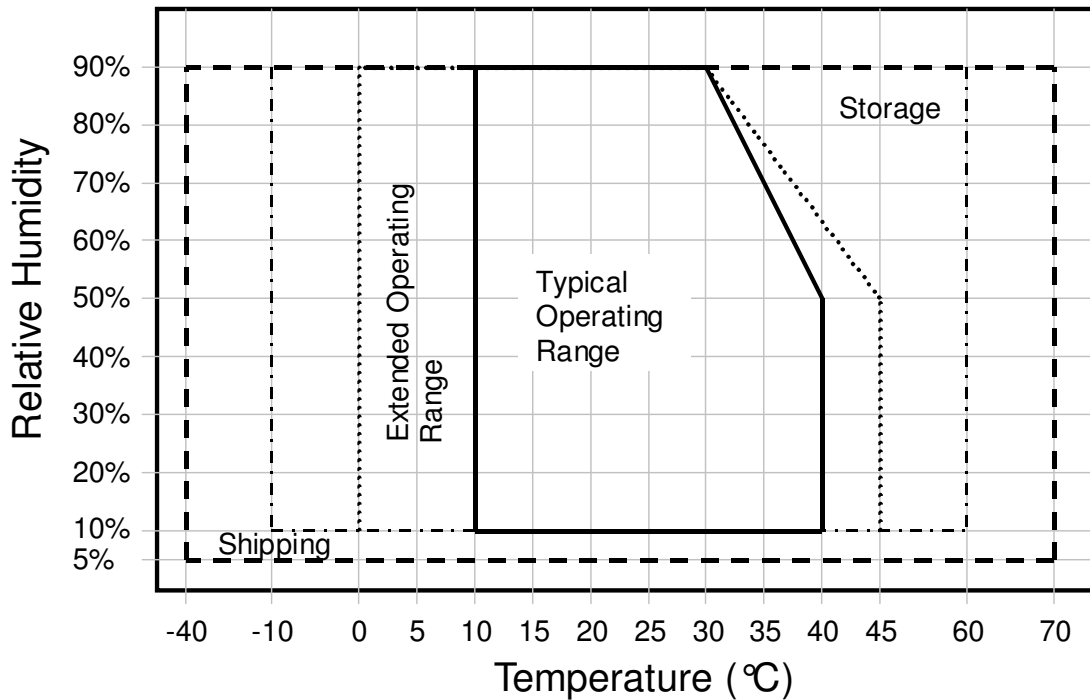

Figure 14 Environmental Conditions: Typical Operating Range

Typical Operating Range:	10°C to 40°C / 50°F to 104°F
*Extended Operating Range:	0°C to 45°C / 32°F to 113°F+
Storage:	-10°C to 60°C / 14°F to 140°F
Shipping:	-40°C to 70°C / -40°F to 158°F

* Exposure to high or low temperatures for periods of greater than 48 hours will lead to significantly reduced cartridge life. The Typical Operating Range provides full printer reliability. The Extended Operating Range may degrade the reliability of the printer and life of the cartridge.

Relative Humidity

Operating:	10% to 90% (<i>non-condensing</i>)
Storage:	10% to 90% (<i>non-condensing</i>)
Shipping:	5% to 90% (<i>non-condensing</i>)

Media Specifications

HP Ink Cartridges

For complete print cartridge specifications refer to the **HP C6602A** Specification.

Print cartridge specification	HP C6602A⁷
Cartridge arrangement	12 vertical nozzles
Typical print dot diameter	0.0100" (0.254 mm)
Vertical dot pitch	0.0104" (0.264 mm) or 96 dpi
Cartridge life	6 million characters at 16 dots per character (average)
Cartridge Color	Black and/or Red, Blue, Green

(All cartridge information based on HP test data.)

Ink Cartridge Operating Conditions (maximum ratings)

Parameter	Minimum	Maximum	Units	Conditions
Shelf Life [1]		24	Months	At 23oC in shipping package
Out of Package Life [1]		6	Months	At 23oC outside shipping package
Non-operating Temperature	100 - 30	+ 60	oC	48 Hours [2]
Non-operating Altitude		10,000	Meters	In sealed container

Table 12 Ink Cartridge Maximum Operating Conditions

Note 1: Total life is Shelf Life (from date of manufacture) plus Out of Package Life.

Note 2: Exposure to high and low temperatures, or long exposure times near specification limits, significantly reduce cartridge life. Higher character capacities are achieved by reducing font resolution.

Receipt Paper (one-ply receipt)

Paper feed method	Friction feed
Paper feed pitch	default - 0.125" (1/8" or 3.175 mm)
Paper width	2.976" ± .016" (75.6 ± .4 mm)
Roll diameter	4.0" max. (101.6mm max)
Paper thickness	0.003" - .004" (0.076 - 0.102 mm)
Roll paper core outside Dia.	0.82" - 0.85" (20.8 – 21.6 mm) Dia.
Roll paper core inside Dia.	0.45" - 0.50" (11.4 – 12.7 mm) Dia.
Typical roll footage	330 feet (100 m)
Paper low indicator	Optional Paper Low Sensor based on paper roll diameter.
Receipt paper out	About 1.0" (25 mm) of paper remaining

⁷ Print cartridge specifications are controlled by Hewlett Packard. Information here is for reference only.

Receipt Printing

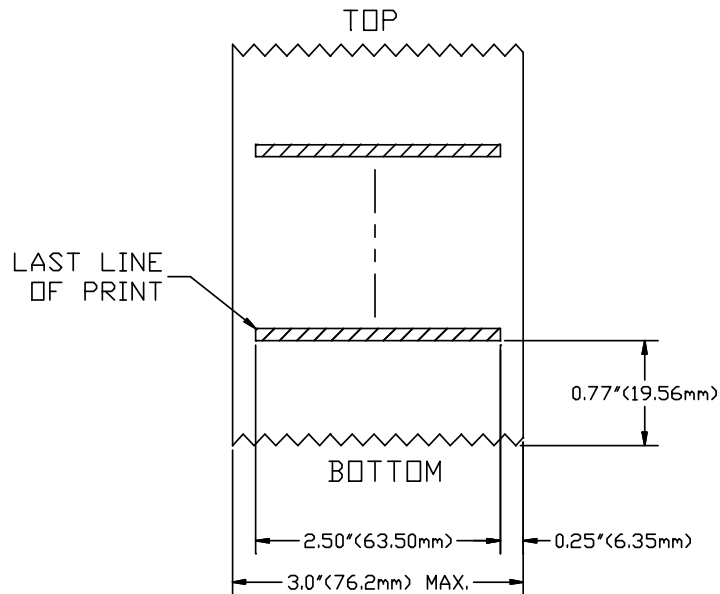

Figure 15 Receipt Printable Area

Receipt Printing, Auto-cutter Position

The paper tear off is positioned 0.77" (19.56 mm) from the last line of print. The Auto-cutter is positioned 1.06" (26.92 mm) from the last print line.

Paper and Core Diameter

To insure proper paper low detection, use paper rolls with a core outside diameter of **.82" to .85" (20.8mm to 21.6mm)**, and an inside diameter of **.45" to .50" (11.4mm to 12.7mm)**. Paper roll width is **3.0" ± .02" (76mm ± .5mm)**. Adjustment and operational results may vary if other thickness and width dimensions are used.

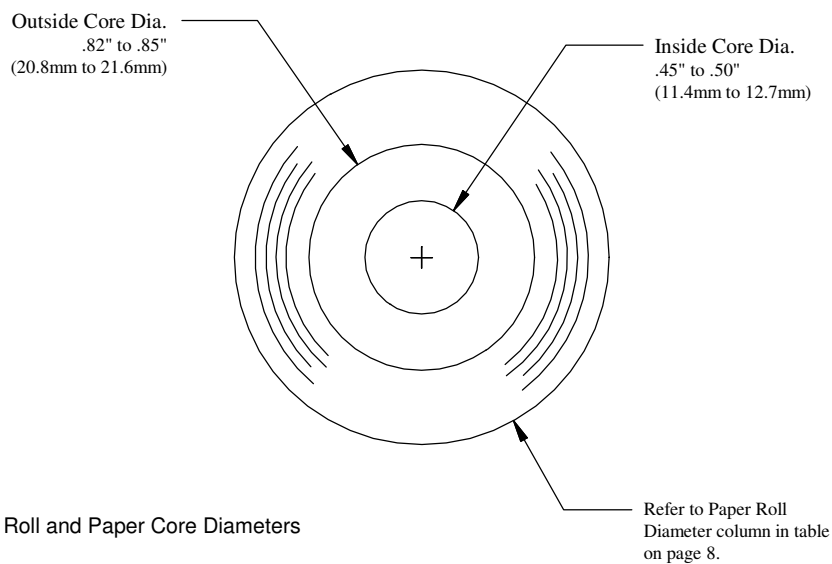

Figure 16 Paper Roll and Paper Core Diameters

Hewlett-Packard Inkjet Cartridges

The HPC6602A Thermal InkJet print head and self-contained ink reservoir for printing on a wide range of common papers. The print cartridge uses HP's Thermal InkJet technology, which is suitable for a broad range of industrial and commercial applications. Non-contact printing operation allows printing on irregular surfaces at variable distances. It also eliminates printer failures due to friction wear or foreign body interference. The absence of any moving parts further enhances reliable operation. The self-contained design and direct interconnect allows fast, simple replacement, and it eliminates the need for any other printer parts such as ribbons, pumps, etc. The small size of the print cartridge makes it very suitable for compact or portable printing devices. Its small size also makes it possible to combine several cartridges to provide larger print zones or higher throughput speeds. Virtually silent operation matches the ergonomic needs of the office, classroom and laboratory. The power consumption of the print cartridge is radically lower than other print technologies. This dramatically reduces the cost of the printer power supply and driver electronics. It also makes battery operation possible, and lowers radiated EMI levels. Driver circuitry can be made with standard off-the-shelf components.

HP Ink Cartridge Specifications and Dimensions

A dot firing frequency of 3000 Hz provides a printing speed of 31.25 inches/sec at 96 dots/inch resolution. This is equivalent to over 375 characters per second at a density of 12 characters per inch. The typical ink capacity of 96 million dots can provide approximately 6M characters using a 96 dots/inch utility font.

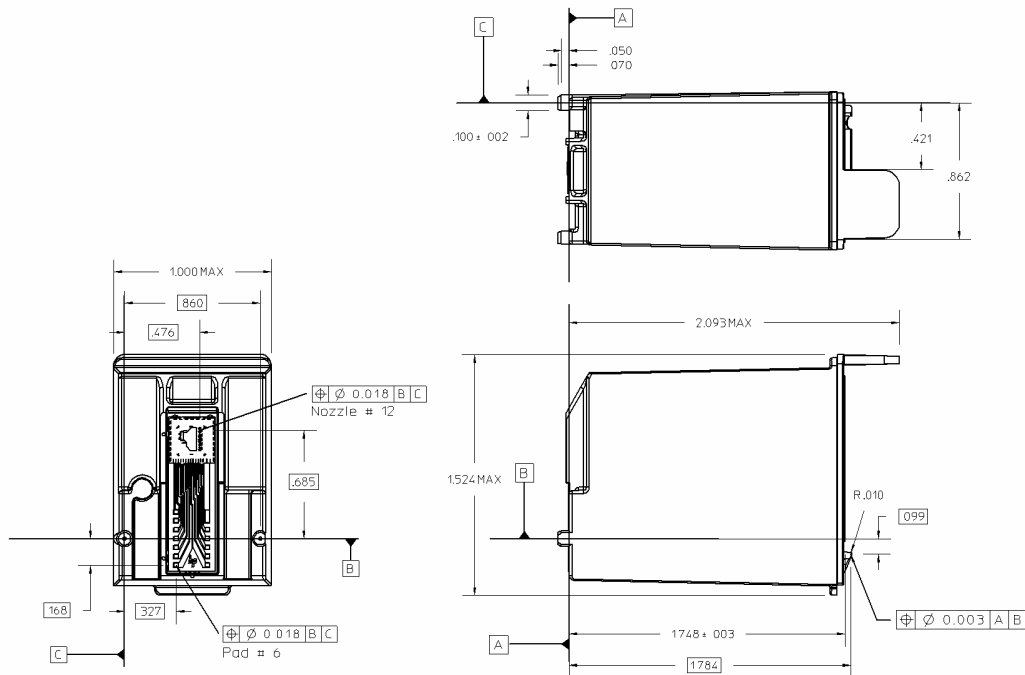

Figure 17 HP Ink Cartridge Specifications

Ink Cartridge Operating Conditions (maximum ratings)

Parameter	Minimum	Maximum	Units	Conditions
Shelf Life [1]		24	Months	At 23oC in shipping package
Out of Package Life [1]		6	Months	At 23oC outside shipping package
Non-operating Temperature	101 30	+ 60	oC	48 Hours [2]
Non-operating Altitude		10,000	Meters	In sealed container

Table 13 Ink Cartridge Maximum Operating Conditions

Note 1: Total life is Shelf Life (from date of manufacture) plus Out of Package Life.

Note 2: Exposure to high and low temperatures, or long exposure times near specification limits, significantly reduce cartridge life. Higher character capacities are achieved by reducing font resolution.

Section 2

Operational Information

- Chapter 4: Using Keypad Controls pg. 26
- Chapter 5: Color Ready Option and Ink Cartridge Usage pg. 33
- Chapter 6: Self-Test Mode pg. 36
- Chapter 7: Configuration Mode..... pg. 37
- Chapter 8: Connections and Communication pg. 38
- Appendix A: Ordering Supplies pg. 43
- Appendix B: Most Frequently Asked Questions pg. 44

Chapter 4: Using Keypad Controls

How to Operate the POSjet 1000 Printer

The POSjet® 1000 Printer uses Hewlett Packard thermal ink jet print cartridges. The HP print cartridge is designed for point of sale applications, has a low ownership cost, and a long life. Like any ink jet printer, the POSjet® 1000 Printer has features that extend the life and reliability of the print cartridge. Unlike consumer ink jet print cartridges, the HP print cartridge does not need to be capped when not in use. Consequently, the POSjet® 1000 is ready to print at all times. Consumer ink jet printers cover and seal the print head to prevent drying when the printer is not in use. The HP cartridge does not need to be sealed. However, the cartridge is still an ink jet cartridge and must have periodic maintenance to keep it functional. Maintenance consists of cleaning the excess ink from the face of the cartridge (“wiping”) and firing ink into a reservoir to clean the print jets (“spitting”). The printer performs these functions as transparently to the host application as possible. However, the printer cannot perform these basic maintenance procedures if the AC power to the printer is removed.

Keypad Buttons

New Cartridge
Feed

Indicator Lights

Power
Error
Paper
Left Cartridge
Right Cartridge

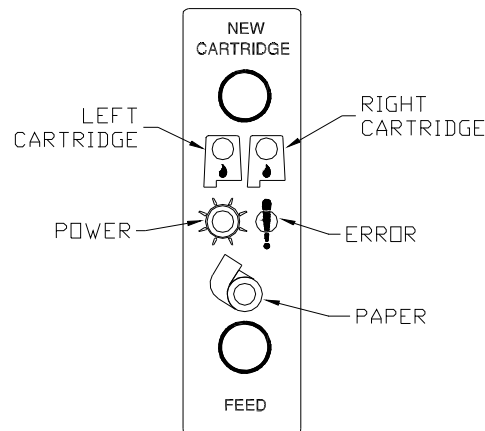

Figure 18 Keypad Buttons and Indicator Lights

Operating the Keypad

The keypad contains two buttons and five indicator lights. These indicator lights are very useful when trying to determine the status of certain printing functions and are important when troubleshooting the POSjet.

* BUTTON	Located on front face of the printer's cabinet
NEW CARTRIDGE	Located on top portion of printer's keypad
FEED	Located on bottom portion of printer's keypad

There is also the * button that is used in conjunction with the keypad controls to perform many operational tasks. The * button is located on the front of the printer and has the primary function of switching the printer ON and OFF.

Do not unplug the printer from its power source. Instead, turn the printer OFF by pressing and releasing the * button. Doing this prepares ink cartridges for periods of inactivity. Turning the printer OFF maximizes the time the ink cartridge(s) can be left without being used. If the AC power cord is removed from the printer for longer than 24hrs., the ink on the face of the cartridge(s) may dry and block the print jets. If the print jets are plugged, the cartridge will have to be replaced. When the printer is turned OFF, it can sit unattended for extended periods without degrading the print cartridge(s).

*** Button**

The POSjet® 1000 has been designed to remain connected to a power source at all times. The * button on the POSjet® 1000 Printer does not completely remove power from the printer. Because of this, the * Button is used to alternately switch the printer between standby/OFF and operational/ON modes. The * Button does not disconnect power to the printer. The printer is truly off only when the AC power supply is disconnected. You will notice that none of the keypad's indicator lights will be on when the printer is in standby/OFF mode. When the printer enters operational/ON mode, the green power indicator light will be activated. The operational state of the POSjet™ can be determined by looking at the Power Indicator Light (LED).

When the * button is pressed or the power down command is received, the POSjet® 1000 Printer enters a standby/OFF low power mode. The printer is not completely off but is in standby/OFF⁸. To keep the print cartridge from completely drying out, the printer must be periodically used. To assure periodic use, the printer occasionally wakes from standby/OFF mode, performs head maintenance, and goes back into standby/OFF. If the printer is completely powered off, head maintenance cannot occur, and overtime, will result in the ink cartridge drying to a state where they will become inoperative. Because of this, the printer should never be completely powered off for more than a few days.

Standby/OFF mode is remembered even if the power is removed. Whenever power is turned back on, the printer starts, performs Level 0 diagnostics, and re-enters standby/OFF mode.

FEED Button

The FEED button feeds paper through the printer. By pressing the FEED button momentarily, the paper will be fed one line at a time. Pressing and holding the FEED button will make the printer feed paper continuously until the button is released.

NEW CARTRIDGE Button

The NEW CARTRIDGE button has been designed to work with the Left and Right Cartridge Indicator Lights (LED), in a way that allows an operator to monitor and replace cartridges as ink levels become low. Operator's will receive input from the indicator lights and will then use the NEW CARTRIDGE Button to communicate to the printer when making the desired changes. Although the NEW CARTRIDGE Button functions primarily as a means for an operator to communicate ink cartridge changes to the printer, it is also used to perform a variety of other functions. Cartridge Status Monitoring⁹ As ink is used from the cartridge(s) it is monitored by the printer. When ink is low, the indicator light for the left or right cartridge will blink. After replacing the low cartridge(s), pressing the NEW CARTRIDGE Button will remove the ink low warning light on the indicators.

Pressing the NEW CARTRIDGE button without changing the cartridge will print the ink status. It will not remove the ink low warning unless the cartridge is removed and replaced while the low indication is being displayed. If the cartridge is replaced with a used cartridge, the NEW CARTRIDGE button should not be pressed.

The cartridge low indicator will continue to be displayed until the cartridge is removed, and a New Cartridge is installed and the NEW CARTRIDGE button is pressed.

⁸ The printer draws about four watts of power in standby/OFF mode.

⁹ The printer cannot distinguish between a new, full cartridge and a used cartridge. When a low cartridge is replaced, the printer will reset the ink status to full when the NEW CARTRIDGE button is pressed. Used cartridges should be discarded to assure that they are not re-installed into the printer.

Quick Start Reference to using Keypad Buttons

What Buttons do I use when...	Do this...
Turning the Printer ON	Press and release * Button
Turning the Printer OFF	Press and release * Button
Removing the Ink Low Warning After Installing New Ink Cartridges	Press and release New Cartridge Button immediately after installing new ink cartridge(s).
Cleaning the Ink Cartridges	Press and release New Cartridge Button.
Printing the Ink Level Status	Press and release New Cartridge Button.
Placing the Printer Into Self-Test Mode	<p>Press and release the * Button to turn the printer OFF. (The power indicator light will be off.)</p> <p>Press and hold the NEW CARTRIDGE Button.</p> <p>While holding the NEW CARTRIDGE Button, press and release the * button.</p> <p>When the red, error indicator light blinks, release the NEW CARTRIDGE Button</p> <p>Follow the directions printed on the receipt to select the desired TEST option.</p>
Entering Configuration Mode	<p>Unplug the AC power cord from the printer.</p> <p>Press and hold the FEED button and plug the power cord back into the printer.</p> <p>Continue to hold the FEED button until the Error indicator light begins to blink.</p> <p>Release the FEED button. A receipt will print. This Configuration Summary Receipt shows how your printer is configured. Follow the directions at the bottom of the receipt to change and save settings.</p> <p>See "Changing Printer Configuration" on page 37.</p>

Table 14 Using Buttons Quick Reference Table

Using the NEW CARTRIDGE Button in Self-Test Mode

The NEW CARTRIDGE button may be used to enter the POSjet's self-test mode. To place the POSjet™ in self-test mode first be sure that a paper roll is loaded and that the * button is on. Next, press the * button to turn the printer off. The power indicator light will be off. Press and hold the NEW CARTRIDGE button while pressing the * button to turn power back on to the printer. Continue to hold until the red error indicator light blink. Let go of the NEW CARTRIDGE button. See "Chapter 6: Self-Test Mode", on page 36 for an overview of self-test. The following categories are a list of the tests available on the POSjet® 1000 printer.

TEST-Receipt	TEST-Burn-in
TEST-Graphics	TEST-Bar-Codes
TEST-Print Specs	TEST-RollingASCII
TEST-Pyramid	

Remote Power Down

The POSjet™ Printer has a command that instructs it to enter standby/OFF mode. When the command is issued, the printer performs print cartridge maintenance and enters standby/OFF mode. Unlike pushing the * button, remote power down mode leaves the communications active. All commands except the exit power down command are ignored.

If the * button is pressed after the power down command is issued, the printer will reactivate. If power is lost after the power down command is issued, the printer will remember it is in standby/OFF mode, but will not reactivate the communications link. The * button must be pressed to restart the printer.

Indicator Light Descriptions

The five POSjet™ indicator lights are:

Power LED	Indicates printer activity and non-recoverable errors
Error LED	Indicates problems and probability of recovery
Paper LED	Indicates paper status (paper low)
Left Cartridge LED	Indicates ink levels of left cartridge
Right Cartridge LED	Indicates ink levels of right ink cartridge

Power Indicator Light (LED)

The power indicator light becomes active when the printer is turned ON. If the power indicator blinks alone, the printer is being held in reset by the host. Refer to "Keypad Indicator Troubleshooting Chart", on page 40 for more information on actual keypad indicator light warnings.

Error Indicator Light (LED)

The error indicator light becomes active when the printer is experiencing some type of error. Refer to "Keypad Indicator Troubleshooting Chart", on page 40 for more information on actual keypad indicator light warnings.

Paper Indicator Light (LED)



The paper indicator light indicates when paper is low by blinking. If the paper and error indicators are both continuously lit, the printer is out of paper. The printer will stop printing and wait for the paper to be changed. Refer to "Keypad Indicator Troubleshooting Chart", on page 40 for more information on actual keypad indicator light warnings.

Left and Right Cartridge Indicator Lights (LED)

The printer has two ink cartridge indicators that signal when the ink cartridges are low or removed from the printer. When ink cartridges are low the light will blink. When ink cartridges are removed, the light will blink continuously. The right indicator is for the right cartridge and the left indicator for the left cartridge. Refer to "Keypad Indicator Troubleshooting Chart", on page 40 for more information on actual keypad indicator light warnings.

Cartridge Indicators (LED-left and right)

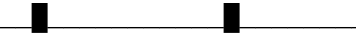
The printer has two ink cartridge indicators that signal the ink cartridge status. The right indicator is for the right cartridge and the left indicator for the left cartridge. If the printer is a single color printer, the left cartridge indicator is used. In most cases, the left cartridge is black, and the right is a highlight color. If both heads are low, the **NEW CARTRIDGE** button only needs to be pressed once; however, both heads must be changed.

Cartridge is low on ink	(1 Blink, pause)	
Cartridge has been removed	(Blinking, error)	

Fault Indicators

The error indicator is the primary fault indicator. It is always on or blinking if a fault has occurred.

Three types of faults exist

Fully-recoverable faults	Paper out or cover open
Semi-recoverable faults	Head Jam
Non-recoverable faults	Component failure

Fully-recoverable and Status

A fully-recoverable error will restart printing exactly where it stopped when the error occurred. Printing will resume after error has been properly addressed. A *status recoverable* error is very similar to a *fully-recoverable* error. Additionally, status is used to display when the printer consumables may need replacing.



Semi-recoverable

A semi-recoverable error is determined by whether or not the printer has to be shut off and turned back on while attending to the problem. The amount of information lost is dependent on the type of error and the state of the information being processed.

Non-recoverable

A non-recoverable error produces information loss.

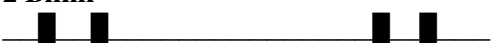
If during normal operation, the **ERROR** indicator is lit and the **POWER** indicator is blinking, a minor error occurred. The **POWER** indicator shows the error by blinking a pattern. Pressing the * button restarts the printer. Blink patterns are defined as follows.¹⁰

1 Blink		(1 blink, pause)
2 Blink		(2 blinks, pause)
3 Blink		(3 blinks pause)

¹⁰ The blink rate is effected by the data received. The faster the data, the faster the printer blinks.

Determining Ink Cartridge Status

The POSjet® 1000 has been designed to monitor ink consumption rates and report ink levels to the user via a printable ink status function. To print out the ink status press the NEW CARTRIDGE button.

When an empty or low ink cartridge is replaced with a new cartridge, pressing the new cartridge button immediately after installing the new cartridge(s) will reset the printer's ink level status to 100%. If this is not done, the printer's ink level status counter will read the new cartridge's ink level as if it were not 100% full. Refer to the following information as a guide for determining when ink cartridges need replacing.

Printer Condition		Keypad Indicator Status				
		Power LED	Error LED	Paper LED	Left Ink LED	Right Ink LED
1	Right Cartridge Low	ON	OFF	OFF	OFF	1 Blink
2	Left Cartridge Low	ON	OFF	OFF	1 Blink	OFF
3	Both Cartridges Low	ON	OFF	OFF	1 Blink	1 Blink
4	Left Cartridge Removed	ON	ON	OFF	ON	OFF
5	Right Cartridge Removed	ON	ON	OFF	OFF	ON

Table 15 Keypad Indicators: Ink Cartridge Status

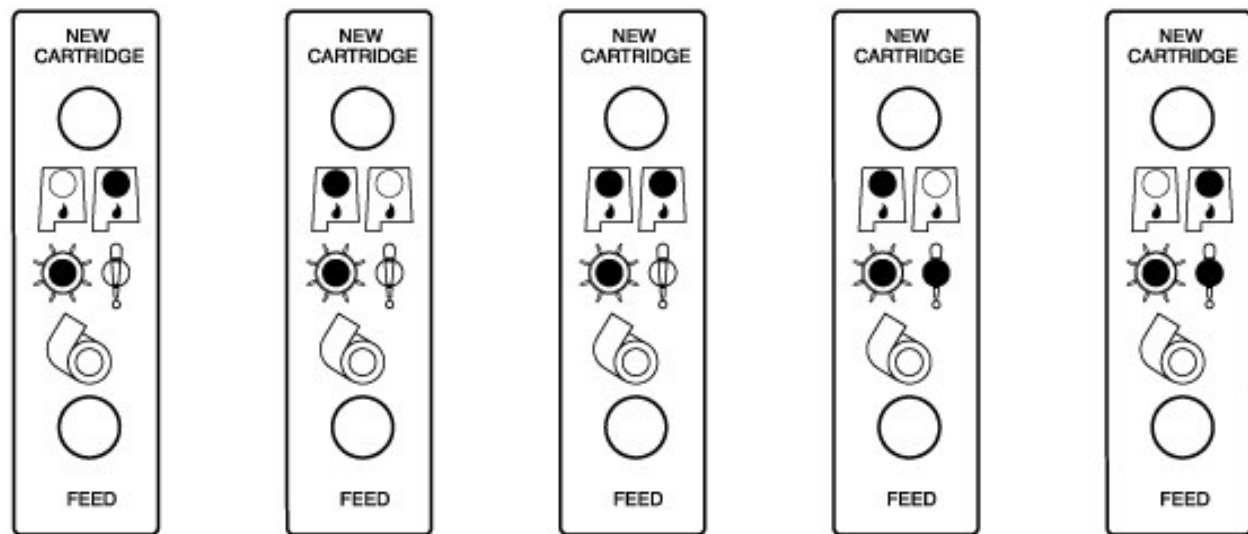

1
Right
Cartridge
Low

2
Left
Cartridge
Low

3
Both
Cartridges
Low

4
Left
Cartridge
Removed

5
Right
Cartridge
Removed

Error Indicator Chart

The following information will assist you in determining specific problems and the respective error light sequences that have been integrated into the POSjet® 1000's keypad. These error messages have been built to help you see when the printer needs general maintenance as well as determine if the problem is one that may produce information loss. This table also displays the extent to which errors will affect the recoverability of information being processed at the time when printing was disrupted.

General problems: Use this table to determine problem type.						
Error Type	Recovery	Power LED	Error LED	Paper LED	Left Cartridge	Right Cartridge
Cover Open	Full	ON	ON	Off	Off	Off
Out of Paper	Full	ON	ON	ON	Off	Off
Paper Low	Status	ON	OFF	Blink	Off	Off
Right Cartridge Low	Status	ON	OFF	OFF	OFF	1 Blink
Left Cartridge Low	Status	ON	OFF	OFF	1 Blink	OFF
Both Cartridges Low	Status	ON	OFF	OFF	1 Blink	1 Blink
Left Cartridge Removed	Full	ON	ON	OFF	ON	OFF
Right Cartridge Removed	Full	ON	ON	OFF	OFF	ON

Table 16 Error Indicator Chart: General Problems

Serious problems: Contact Technical Support for assistance. (877) 7ithaca or (607) 257-8901						
Error Type	Recovery	Power LED	Error LED	Paper LED	Left Cartridge	Right Cartridge
Carriage Jam	Semi	1 Blink	ON	OFF	OFF	OFF
Configuration Error	Semi	2 Blinks	ON	OFF	OFF	OFF
Statistics Update Error	Semi	3 Blinks	ON	OFF	OFF	OFF
Internal Software Error	Semi	4 Blinks	ON	OFF	OFF	OFF
Knife Jam	Semi	5 Blinks	ON	OFF	OFF	OFF
User Store Defective	Semi	6 Blinks	ON	OFF	OFF	OFF
Flash Write Error	Semi	7 Blinks	ON	OFF	OFF	OFF

Table 17 Error Indicator Chart: Serious Problems

Paper Low and Paper Out Sensing

The POSjet® 1000 has been designed with varying levels of paper sensing capabilities. All printers come standard with a paper out sensor located in the paper drive system. Additionally, an optional paper low sensor can be integrated into the printer's cabinetry base assembly. The optional paper low sensor is user adjustable and can be set to several paper remaining settings.

Paper Out Sensing Keypad Indicators

When a paper low occurs, the Paper LED will begin blinking continuously. The amount of time that the printer will continue to feed paper remains decartridgedant on the specific "Paper Remaining Setting" that has been established previously. The Paper Indicator Light will blink continuously until a paper out sensing occurs. When paper out has occurred, the printer will automatically shut down and wait for a new paper roll to be installed. The printer's buffer will hold any remaining information until the paper roll is installed. After the new roll is installed, the printer will draw from the buffer and resume printing at the exact place where it stopped when paper out sensing first occurred.

Chapter 5: Color Ready Option and Ink Cartridge Usage

Overview of Color Ready Option

All POSjet® 1000 optional features are installed at the factory and must be selected when the printer is ordered. The majority of factory options do not need the user to perform any additional setup steps. However, if the color ready option is ordered, users will be required to adhere to specific operational procedures.

Color Ready Configuration

The POSjet® 1000 printer is available with a color ready cartridge carriage but without the second ink cartridge installed. This printer configuration is termed color ready. It is configured to handle single cartridge “black” printing and will not print with a second “color” cartridge installed in the right carriage because it is configured to operate with single cartridges only. When the printer has the second ink cartridge installed, it should be reconfigured to be a two cartridge (color) printer. This can be done through software, or by using the manual configuration mode to change your settings. See “Chapter 7: Configuration Mode”, on page 37.

The following is a list of reminders that will assist you in setting up the printer for correct operation regardless of whether or not your printer is set up to run a single ink cartridge (black only) or with two cartridges (color).

Single Color Setup

The Single Color printer setup is a factory built option. It is configured to handle a single ink cartridge and cannot be field upgraded for Two Color operation. When using the POSjet with a single cartridge setup the left ink carriage should contain a single BLACK cartridge, or a single color ink cartridge.

Printing Setup	Left Cart.	Right Cart.	Wiper	Selecting the configuration menu settings:
Single Cartridge Operation	Black or any color	None	Fixed	Factory built option. Not field upgradeable. No configuration required for operation.

Table 18 Single Color Printer-Color Configuration Details

Two Color Ready Setup (single cartridge setup)

The Two Color Ready setup allows the POSjet to operate as a Single Color printer with the option of reconfiguring the printer for Two Color (multiple color) printing. This reconfiguration can be done at anytime by TransAct or any one of our certified service technicians.

A printer that is setup with the Two Color Ready option but has no second cartridge in the right carriage always needs to have the orange colored, plastic spacer in the right carriage. There is an auto-sense feature that attempts to auto sense the presence of a second cartridge. This auto-sense will momentarily re-configure the printer for two cartridge operation. The auto-sense is performed when power is applied to the printer (not with the standby/OFF button). If the printer is power cycled without the second cartridge, the printer will revert back to single cartridge operation. When the printer has the second cartridge installed, it should be reconfigured through software, or with manual configuration to be a two cartridge (color) printer. In addition to this, the printer needs the following configuration settings:

Printing Setup	Left Cart.	Right Cart.	Wiper	Selecting the configuration menu settings: See “Changing Printer Configuration” on page 37 for information on how to change configuration settings.	
Two Color Ready Operation	Black or any color	Orange spacer required	Dual	Config. Menu Option: Left Cartridge Color Black	Config. Menu Option: Right Cartridge Color Color Ready

Table 19 Two Color Ready Operation-Color Configuration Details

Two Color Setup (two cartridge setup)

Two Color Operation setup allow the POSjet to operate as a two color printer. Unlike the Two Color Ready setup, the Two Color setup does not use the orange colored spacer in the right carriage. Instead, the right carriage holds a color ink cartridge, and is used along with the desired ink cartridge in the left carriage to produce two color printing. Color ink cartridges do not work in the left carriage socket. Use only black ink cartridges in the left carriage socket. The color of the second cartridge should be configured into the POSjet™1000 printer. The printer should be set to Red, Green, or Blue. If the cartridge that is installed is not one of these primary colors, the nearest primary color should be selected. For example if the cartridge is Orange, the nearest primary color is Red. A printer that is setup to print multiple colors needs to have the following configuration settings:

Printing Setup	Left Cart.	Right Cart.	Wiper	<i>Selecting the configuration menu settings: See "Changing Printer Configuration" on page 37 for information on how to change configuration settings.</i>	
Two Cartridge Operation	Black or any color	Red Green Blue	Dual	Left Cartridge Menu Black Red Green Blue	Right Cartridge Menu Red Green Blue

Table 20 Two Color Operation-Color Configuration Details

Deactivating the Two Color Setup (back to Single Color setup)

A printer that is setup for Two Color printing can be reconfigured to print using only a single cartridge. This can be achieved by resetting the left cartridge color to "BLACK" and the right cartridge color to "COLOR READY" using the configuration menu. When "Color Ready" is activated, all printing data will be sent to the left cartridge and the printer will be able to print using a single cartridge in the left carriage only. When "Color Ready" is activated, the orange spacer needs to be re-inserted into the right carriage.

Using Ink Cartridges

- It is not possible to configure the printer to operate with two black cartridges.
- Do not store a spare cartridge in the second carriage socket position.
- Always store extra ink cartridges in the uncartridgeed original HP packaging until needed.
- Do not replace an empty ink cartridge with anything but a new ink cartridge that is approved and compatible with the printer

Care of Ink Cartridges

Once a print cartridge is unsealed, it should be placed in an operating printer. If a printer is taken out of service, the print cartridge(s) should be removed and discarded.

Determining Ink Cartridge Status

The POSjet® 1000 has been designed to monitor ink consumption rates and report ink levels to the user via a printable ink status function. To print out the ink status press the NEW CARTRIDGE button.

When an empty or low ink cartridge is replaced with a new cartridge, pressing the new cartridge button immediately after installing the new cartridge(s) will reset the printer's ink level status to 100%. If this is not done, the printer's ink level status counter will read the new cartridge's ink level as if it were not 100% full. Refer to the following information as a guide for determining when ink cartridges need replacing.

Printer Condition		Keypad Indicator Status				
		Power LED	Error LED	Paper LED	Left Ink LED	Right Ink LED
1	Right Cartridge Low	ON	OFF	OFF	OFF	1 Blink
2	Left Cartridge Low	ON	OFF	OFF	1 Blink	OFF
3	Both Cartridges Low	ON	OFF	OFF	1 Blink	1 Blink
4	Left Cartridge Removed	ON	ON	OFF	ON	OFF
5	Right Cartridge Removed	ON	ON	OFF	OFF	ON

Table 21 Keypad Indicators: Ink Cartridge Status

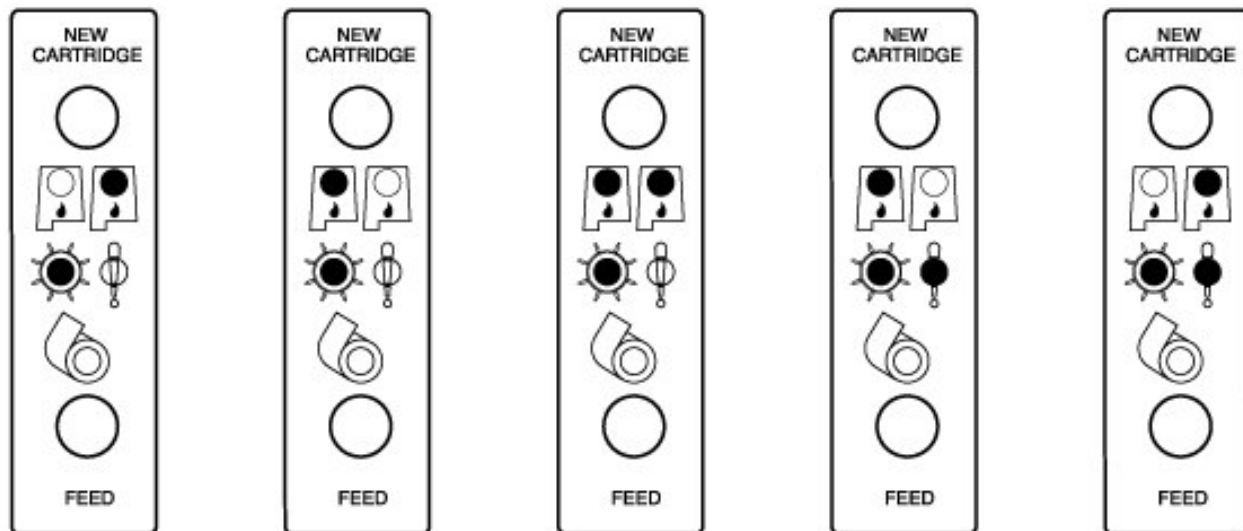

1
Right
Cartridge
Low

2
Left
Cartridge
Low

3
Both
Cartridges
Low

4
Left
Cartridge
Removed

5
Right
Cartridge
Removed

Chapter 6: Self-Test Mode

It is important to insure that the printer will perform a self-test. This isolates printing problems to something other than the operation of the printer itself. The POSjet has a total of eight self-test options with two designed to be useful when performing on-site evaluations. These two tests are the only options that should be used to test your printer. The other six testing options are used for printer demonstrations and factory setup by TransAct. Use the following two TEST options when trying to discover a printing problem.

TEST-Receipt

The receipt test is the primary test option to use when determining if the printer is functioning correctly. The receipt test is mostly used during the early stages of troubleshooting to eliminate the possibility that the problem is occurring with the printer. If the printer experiences a failure, and the error indicator light is activated, call TransAct's Ithaca Facility's Technical Support Department.

TEST-Print Configuration

The print configuration test is a quick and easy way for you to see how your printer has been configured at the factory without actually entering into configuration mode. A large percentage of initial installation and setup problems can be attributed to the printer's configuration not matching the user's system settings. Using this test will show you exactly what your printer's current configuration settings are.

Disregard the following options when cycling through the menu. The following 6 self-test options do not need to be run in order to determine if the printer is running properly. These test options are only used for printer demonstrations and factory setup.

TEST-Graphics

TEST-Print Specs

TEST-Pyramid

TEST-Burn in

TEST-Bar Codes

TEST-Rolling ASCII

Placing the Printer In Self-Test Mode

1. Press and release the * button to turn the printer OFF. (The power indicator light will be off.)
2. Press and hold the NEW CARTRIDGE button.
3. While holding the NEW CARTRIDGE button, press and release the * button.
4. When the red, error indicator light blinks, release the NEW CARTRIDGE button
5. Follow the directions printed on the receipt to cycle through and select the desired TEST option.

Exiting Self-Test Mode

Exit self-test mode at any time by pressing the * button to place the printer back into ON.

Self-Test Hints and Suggestions

- If the printer fails to complete or enter into self-test mode disconnect it from the application system.
- Contact TransAct's Ithaca Facility's Technical Support Department if self-test mode fails in any way.

Chapter 7: Configuration Mode

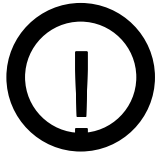

TransAct highly recommends that any attempt at configuring the POSjet be made by a Certified Service Technician who has successfully completed training on the POSjet® 1000. TransAct is not responsible for printer's that are configured by anyone other than a trained technician.

Changing Printer Configuration

If you are experiencing incompatibility between your printer and your system there are two ways to change the configuration of the POSjet® 1000 to match your system. The first is to use the manual configuration sequence by using the keypad controls. To provide a faster, easier way to configure or reconfigure the POSjet printer, a remote CONFIG program is available and typically used by system integrators. To obtain more information, or the latest version of the CONFIG program, call our Sales Department.

!ATTENTION!: Make sure these configuration parameters are compatible with your system.

Parallel Printer

Emulation
Carriage Return Options

Serial Printer

Emulation
RS-232 Serial Interface (baud rate)
Carriage Return Options

TransAct recommends that you **ONLY CHANGE THE ABOVE SETTINGS** and does not recommend that these reconfigurations be made by anybody but a trained service technician who has successfully completed training on the POSjet® 1000. Please remember that these settings are only a few of the possible configurable categories. If you continue to experience incompatibility issues after changing these settings to match your system, contact TransAct's Technical Support Department for assistance.

Placing the Printer In Configuration Mode (Manual Configuration Mode)

1. Unplug the AC power cord from the printer.
2. Press and hold the FEED button and plug the AC power cord back into the printer.
3. Continue to hold the FEED button until the error indicator light begins to blink.
4. Release the FEED button. A receipt will print. This Configuration Receipt shows how your printer is configured. Follow the directions at the bottom of the receipt to change and save configuration settings.

Using the New Cartridge Button in Configuration Mode

What do you want to do?	Do this...
Scroll through the Configuration menu	Press and quickly release the New Cartridge Button.
Change specific settings	Press and hold the New Cartridge Button.
Exit Configuration Mode	Press and release the * Button at any time.

Table 22 How to Change Configuration Settings

Chapter 8: Connections and Communication

Parallel Interface

There are two parallel interface cards. One is a 25-pin D-shell connector. The pin-out is such that the printer interfaces to a standard IBM PC parallel printer interface with a one-to-one cable. The second card type provides the same interface with a standard, 36-pin Centronics connector. Both cards provide a dual cash drawer interface. The following table lists interface signals and pin definitions for both types of parallel interface cards.

25-pin D-Shell **IEEE 1284-A**
36-pin Centronics **IEEE 1284-B**

Parallel Pin Assignments

25-pin Connector	36-pin Connector	Signal	Description	Direction
Pin 1	Pin 1	STROBE	Clock data to printer	Host to Printer
Pins 2-9	Pins 2-9	D0 - D7	Data	Host to Printer
Pin 10	Pin 10	ACK\	Printer accepted data	Printer to Host
Pin 11	Pin 11	BUSY	Printer busy	Printer to Host
Pin 12	Pin 12	PE	Paper Out/Status	Printer to Host
Pin 13	Pin 13	SLCT	Printer selected	Printer to Host
Pin 14	Pin 14	AUTOFD	Autofeed paper	Host to Printer
Pin 15	Pin 32	FAULT\	Printer error	Printer to Host
Pin 16	Pin 31	INIT\	Initialize printer	Host to Printer
Pin 17	Pin 36	SLIN	Select printer	Host to Printer
	Pin 17	FG	Frame ground	Printer to Host
	Pin 18	+5V	Peripheral logic high	Printer to Host
Pins 18-25	Pins 16, 19-30	GND	Ground	

Table 23 Parallel Interface Pin-outs

Serial Interface

There are two serial interface cards. One is a 9-pin D-shell connector. The pin-out is such that the printer interfaces to a standard IBM PC Serial printer interface with a Serial Null Modem cable. The second adapter provides the same interface with a standard 25-pin D-shell connector. Both cards provide a dual cash drawer interface. The following table lists interface signals and pin definitions for both types of serial interfaces. The POSjet requires an RS-232C shielded cable, no more than 50 feet long.

Serial Pin Assignments

9-pin	25-pin	Signal	Description
Pin 1	Pin 8	N/C	No Connection
Pin 2	Pin 3	RX	Receive Data
Pin 3	Pin 2	TX	Transmit Data
Pin 4	Pin 20	DTR	Data Terminal Ready
Pin 5	Pin 7	GND	Signal Ground
Pin 6	Pin 6	DSR	Data Set Ready
Pin 7	Pin 4	RTS	Request to Send
Pin 8	Pin 5	CTS	Clear to Send
Pin 9	Pin 11	N/C	No Connection

Table 24 Serial Interface Pin-outs

Cash Drawer Interface Description and Specifics

The POSjet® 1000 Printer supports dual cash drawers with status. The driver in the printer is capable of supplying 24 V DC at up to 1.5 amps and 250 milliseconds. The POSjet® 1000 Printer defines cash drawer closed as switch open. If the drawer is disconnected, the printer considers it closed. Since the printer does not act on the cash drawer status, the application can interpret cash drawer status any way it wants.

- Connector Type (standard) Single RJ12 connector with 24V sink drivers
- Voltage 24 volts (Refer to power supply specification)
- Current..... 1 amp maximum with current limit
- Pulse Duration 250 msec maximum
- Drawer Status Open/close drawer status to printer

Cash Drawer Pin Assignments

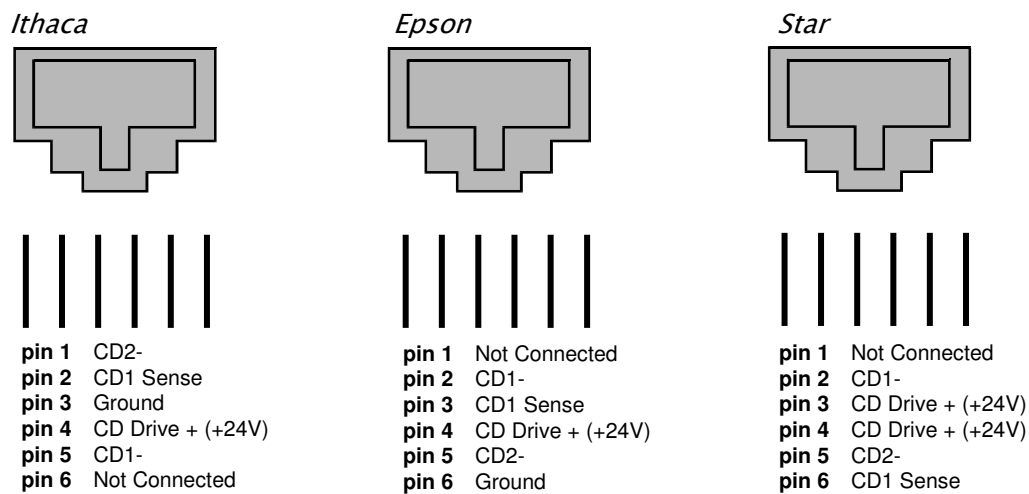

The printer can be configured for one of three cash drawer configurations. The interface card has a 14-pin header with a 10-pin shunt installed on it. The shunt position defines the configuration of the cash drawer. Refer to the markings on the board when determining where the shunt should be installed to work in the three different configurations.

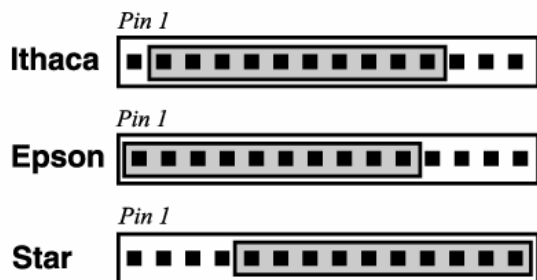

Figure 19 Cash Drawer Pin-outs

Chapter 9: Operational Troubleshooting

Keypad Indicator Troubleshooting Chart

General problems: Use this table to determine problem type					
Error Type	Power LED	Error LED	Paper LED	Left Cartridge	Right Cartridge
Cover Open	ON	ON	Off	Off	Off
Out of Paper	ON	ON	ON	Off	Off
Paper Low	ON	OFF	Blinking	Off	Off
Right Cartridge Low	ON	OFF	OFF	OFF	1 Blink
Left Cartridge Low	ON	OFF	OFF	1 Blink	OFF
Both Cartridges Low	ON	OFF	OFF	1 Blink	1 Blink
Left Cartridge Removed	ON	ON	OFF	ON	OFF
Right Cartridge Removed	ON	ON	OFF	OFF	ON

Table 25 Keypad Indicators: General Problems

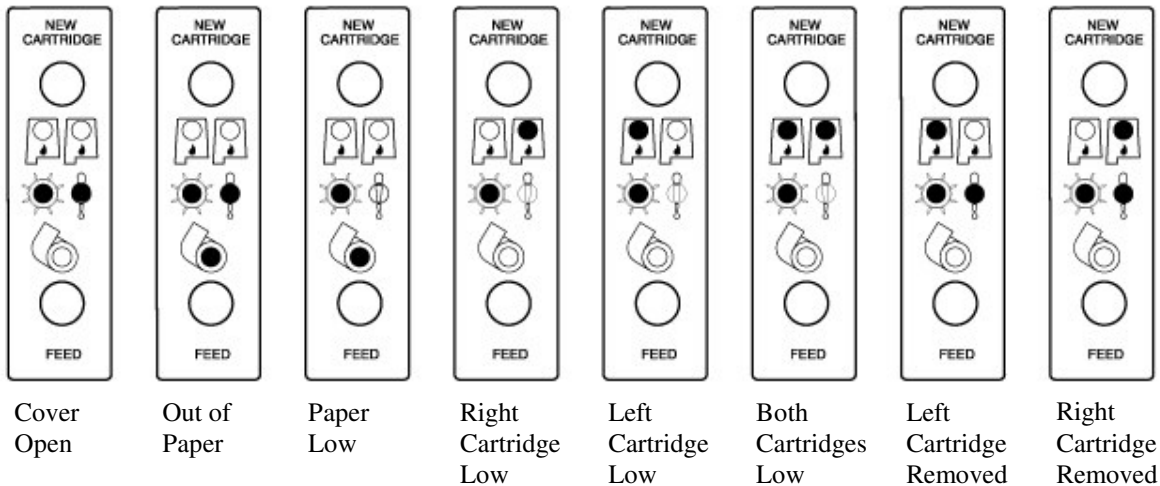

Serious Problems Indicator Warnings

The POSjet will use a combination of the Power and Error Indicator Lights to signal serious problems. In most cases, you can tell if the printer is experiencing a specific type of serious problem by counting the number of times that the POWER button blinks. Most serious problems should be addressed by a TransAct technical support specialist. See “Contacting TransAct’s Ithaca Facility” on page iv.

Serious problems: Contact Technical Support for assistance. (877) 7Ithaca or (607) 257-8901					
Error Type	Power LED	Error LED	Paper LED	Left Cartridge	Right Cartridge
Carriage Jam	1 Blink	ON	OFF	OFF	OFF
Configuration Error	2 Blinks	ON	OFF	OFF	OFF
Statistics Update Error	3 Blinks	ON	OFF	OFF	OFF
Internal Software Error	4 Blinks	ON	OFF	OFF	OFF
Knife Jam	5 Blinks	ON	OFF	OFF	OFF
User Store Defective	6 Blinks	ON	OFF	OFF	OFF
Flash Write Error	7 Blinks	ON	OFF	OFF	OFF

Table 26 Keypad Indicators: Serious Problems

Correcting Common Operating Problems

This troubleshooting section provides solutions to problems that may occur with your printer. Use the following series of tables to determine printing problems. It is highly recommended that you maintain a history of reported problems and the actions you took to identify or resolve problems. This information can help you isolate later problems and anticipate or avoid others. In particular, you should record the problem description, including a brief explanation of the symptoms. The following is a list of possible problem areas. These categories have been established to assist you with preliminary troubleshooting information.

- Keypad Lights Are Not Working
- Printer Will Not Print (Error Light ON)
- Printer Will Not Print (Error Light OFF)
- Printer Prints With Missing Dots In Characters
- Printer Sounds Like It's Printing But Nothing Prints
- Printer Will Not Load Or Feed Paper

Keypad Lights Are Not Working	
Possible Cause	Remedy
Poor Connections/No Power	Check to see if AC power cord is plugged into wall outlet.
	Check the AC power cord connection on back of the printer.
	Check to see if printer is turned ON.

Table 27 Troubleshooting: Keypad Lights Will Not Work

Printer Will Not Print (Error light ON)	
Possible Cause	Remedy
Ink Cartridge Not Installed	Install new ink cartridge(s). See "Installing Ink Cartridges on page 9.
Paper Cover Open	Close both of the printer's covers, making sure that the rear paper cover is snapped into place.
	Check paper path for debris and/or jammed paper which might cause the covers not to close fully.
Paper Not Installed	Install a new paper roll. See "Installing a New Paper Roll Using Insta-Load™", on page 10.
Carriage Jammed	Open the printer's covers and clear any paper or debris from around the carriage.

Table 28 Troubleshooting: Printer Will Not Print (Error Light ON)

Printer Will Not Print (Error Light OFF)		
Possible Cause	Remedy	
Printer Is Not Responding To Any Input	Check Printer in Self-Test. See "Placing the Printer In Self-Test Mode", on page 36.	
	<table border="0"> <tr> <td style="vertical-align: top;"><i>If Self-Test prints</i> Check communication cable connection, and verify printer's communication configuration settings.</td> <td style="vertical-align: top;"><i>If Self-Test does not print</i> Contact TransAct's Ithaca Facility. See "Contacting TransAct's Ithaca Facility", on page iv.</td> </tr> </table>	<i>If Self-Test prints</i> Check communication cable connection, and verify printer's communication configuration settings.
<i>If Self-Test prints</i> Check communication cable connection, and verify printer's communication configuration settings.	<i>If Self-Test does not print</i> Contact TransAct's Ithaca Facility. See "Contacting TransAct's Ithaca Facility", on page iv.	

Table 29 Troubleshooting: Printer Will Not Print (Error Light OFF)

Printer Prints With Missing Dots In Characters		
Possible Cause	Remedy	
Ink Buildup On Ink Cartridges	Press New Cartridge Button 2-3 times and try to print again. The New Cartridge Button cycles the printer's ink cartridge cleaning wipers.	
	If New Cartridge Button Works: Resume printing and remember to use the * Button to place the printer OFF while not in use.	If New Cartridge Button Does Not Work: Replace with a new ink cartridge. Dispose of the used ink cartridge. Resume printing.

Table 30 Troubleshooting: Printer Prints With Missing Dots in Characters

Printer Sounds Like It's Printing But Nothing Prints		
Possible Cause	Remedy	
Paper Path Jammed	Open both covers and check to see if there is any debris in the paper path that may cause paper not to feed correctly.	
	If You See Debris: Unplug printer and clear any debris. Plug printer back in Press and hold the feed Button to advance paper. Try printing again.	If There Is No Debris: Press New Cartridge Button 2-3 times to cycle the printer's automatic cleaning mechanism. Try printing again. If the problem still exists, contact TransAct's Ithaca Facility.
	Press New Cartridge Button 2-3 times and try to print again. The New Cartridge Button cycles the printer's ink cartridge cleaning wipers.	
	If New Cartridge Button Works: Resume printing and remember to use the * Button to place the printer OFF while not in use.	If New Cartridge Button Does Not Work: Replace with a new ink cartridge. Dispose of the used ink cartridge.
	If the problem still exists, contact TransAct's Ithaca Facility. See Contacting TransAct's Ithaca Facility on page iv.	

Table 31 Troubleshooting: Printer Sounds Like It's Printing But Nothing Prints

Printer Will Not Load Or Feed Paper		
Possible Cause	Remedy	
Covers Open	Close both the printer's covers making sure that the rear paper cover is fully snapped into place.	
	Check paper path for debris and/or jammed paper which might cause the covers not to fully close.	
Paper Path Jammed	Open both covers and check to see if there is any debris in the paper path that may cause paper not to feed correctly.	
	If You See Any Debris: Unplug printer and clear any debris. Plug printer back in and press and hold the feed Button to advance paper.	If There Is No Debris: Call TransAct's Ithaca facility. See "Contacting TransAct's Ithaca Facility", on page iv.

Table 32 Troubleshooting: Printer Will Not Load or Feed Paper

Appendix A: Ordering Supplies

Ordering Supplies

POSjet® supplies can be ordered easily direct from the TransAct website (www.transact-tech.com) or our telephone number within the US toll free: (877) 7ithaca. (other inquires: (607) 257-8901). When calling by phone, please ask for the Sales Department. See “Contacting TransAct’s Ithaca Facility” on page iv for more details.

Consumable Kits	Stock Number
12 rolls paper/1 Blk. Ink Cartridge (Standard Grade)	100-03429
20 rolls paper/1 Blk. Ink Cartridge (Standard Grade)	100-03430
12 rolls paper/1 Blk. Ink Cartridge (Premium Grade)	98-03508
20 rolls paper/1 Blk. Ink Cartridge (Premium Grade)	98-03509

Table 33 Paper Ordering Information

Receipt Paper	Type	Dimensions	Stock Number
24 Roll Case	(Ithaca Inkjet 295S)	See page 22.	98-02022
32 Roll Case	(Ithaca Inkjet 300P)		98-03505
120 Roll Case	(Ithaca Inkjet 300P)		98-03507
24 Roll Case	(Ithaca Inkjet 300P)		98-06697

Table 34 Paper Ordering Information

Ink Cartridges: 3 Pack	Supplier	Stock Number
3 Pack Black	Transact's Ithaca Facility	100-02347
3 Pack Red	Transact's Ithaca Facility	100-02349
3 Pack Blue	Transact's Ithaca Facility	100-02353
3 Pack Green	Transact's Ithaca Facility	100-02351
Ink Cartridges: 6 Pack	Supplier	
6 Pack Black	Transact's Ithaca Facility	100-02348
6 Pack Red	Transact's Ithaca Facility	100-02350
6 Pack Blue	Transact's Ithaca Facility	100-02354
6 Pack Green	Transact's Ithaca Facility	100-02352

Table 35 Ink Cartridge Ordering Information

Cables	Stock Number
110V Power Cable (USA)	98-02174L
220V Power Cable (Australia)	98-02178L
230V Power Cable (International)	98-02175L
230V Power Cable (IND/South Africa)	98-02179L
240V Power Cable (UK)	98-02176L
Parallel Communication Cable	
25-pin male to 25-pin male	253-9800007
36-pin Centronics to 25-pin male	253-9800002
Serial Communication Cable	
9-pin Female to 9-pin Female	10-2020
9-pin Female to 25-pin Female	10-2021

Table 36 Cables Ordering Information

Domestic and International power cables available. Call for more information

Drivers Available

Windows® 95/98/Me Print Driver and Documentation	98-9171
Windows® 2000/NT 4.0 Print Driver and Documentation	98-9172
OPOS Print Driver Manual	100-9730
OPOS Print Driver Disk 1 / Disk 2	100-9731 / 100-9732
Software Developer's Toolkit(CD-ROM)	100-02440

Appendix B: Most Frequently Asked Questions

How do I...	Do this...
Change Paper Rolls	Open rear paper cover. Insert new roll so that paper unwinds from the bottom and rests on the top of the front cover. Close both covers. The paper will load automatically. See "Installing a New Paper Roll Using Insta-Load™", on page 10.
Feed Paper	Press and release the FEED Button for a single line. Press and hold the FEED Button for continuous feed.
Change Ink Cartridges <i>DO NOT USE ANYTHING OTHER THAN NEW CARTRIDGES WHEN REPLACING EMPTY CARTRIDGES</i>	Open front cover. Take ink cartridge(s) out of carriage system and replace with new cartridge(s). Press and release New Cartridge Button. See "Installing Ink Cartridges", on page 9.
Remove The Ink Low Warning After Installing New Ink Cartridges	Press and release the New Cartridge Button immediately after loading the new ink cartridges.
Clean Ink Cartridges	Press and release the New Cartridge Button 2-3 times. If cartridge still is not working correctly, replace the cartridge(s).
Print Ink Level Status	Press and release the New Cartridge Button.
Enter Self-Test Mode	<ol style="list-style-type: none"> 1. Press and release the * Button to turn the printer OFF. (The power indicator light will be off.) 2. Press and hold the NEW CARTRIDGE Button. 3. While holding the NEW CARTRIDGE Button, press and release the * Button. 4. When the red, error indicator light blinks, release the NEW CARTRIDGE Button 5. Follow the directions printed on the receipt to cycle through and select the desired TEST option.
Enter Configuration Mode	First, unplug the AC power cord from the printer. Next, press and hold the FEED Button while plugging the cord back in. Continue to hold the FEED button until the Error indicator light begins to blink. Release the FEED Button.
Cycle Through Configuration Menu	Follow the directions that print on the configuration receipt after entering Configuration Mode.
Save Configuration Settings	Press and release the * Button at any time.
Exit Self-Test Mode	Press and release the * Button at any time.
Exit Configuration Mode	Press and release the * Button at any time.

Table 37 Most Frequently Asked Questions

Index

A

Appendix A	
Ordering Supplies	43

C

Cables	
Restrains	4
Caring for Ink Cartridges	34
Cartridge Status	31, 35
Cash Drawer Cable	
Connecting	5
Cash Drawer Connector	
Pin Assignments	6
Changing Printer Configuration.....	37
Chapter 4	
Specifications	13
Chapter 9	
Operational Troubleshooting	40
Character Generation	18
Character Pitch	20
Color Ready Option	
Configuration	33
Overview.....	33
Communication Cables.....	5
Configuration	
Color	14
Color Ready.....	14
Single Cartridge Operation	14
Two Cartridge Operation	14
Configuration Mode	
Using.....	37
Using New Cartridge Button.....	37
Configuration Settings	11
Configurations	14
Connecting Cash Drawer Cables	6
Connecting Parallel Cable	5
Connecting Power and Communications	3
Connecting Serial Cable	5
Connecting the Power Cord-no power supply	4
Connecting the Power Cord-with power supply	3
Connections	
Cash Drawer Interface Description	39
Cash Drawer Pin Assignments.....	39
Parallel Interface	38
Parallel Pin Assignments	38
RS-232 Serial Pin Assignments	38
Serial Interface.....	38
Connections and Communications	38
Copyright.....	i
Correcting Common Startup Problems	12

D

DC Power Requirements	16
dimensions of printer	15

E

Emulations	
Citizen 3500.....	14
EPOS	14
IPCL Codes.....	14
Standard	14

Star	14
Error Indicator Chart	32
Exiting Self-Test Mode	36

F

Features	
Color Ready Options	33

H

Hewlett-Packard Inkjet Cartridges	24
How to Operate the POSjet 1000 Printer	26

I

Indicators	
LED indicator	
Cartridge left.....	29
cartridge right	29
LED indicator	
Paper.....	29
Indicators	
Fault	30
LED indicator	
Error	29
Power.....	29
Ink Cartridge	
Operating Conditions	22, 24
Single Cartridge Operation.....	33
Ink Cartridge Status	
Determining Ink Cartridge Status.....	31, 35
Ink Cartridges	
Caring For Ink Cartridges.....	34
Checking Status.....	31, 35
Feature Configuration.....	34
Ordering	43
Single Cartridge Operation.....	33
Specifications	24
Two Cartridge Operation.....	34
Using	34
Installation	
Step 1	
Unpacking the Printer.....	2
Step 2	
Connecting Power and Communications.....	3
Step 3	
Paper Low Setup.....	7
Step 4	
Loading Ink Cartridges and Paper	9
Step 5 Confirm Configuration Settings	11
Step-by-Step Instructions	1
Troubleshooting Setup Problems	12
Installing a New Paper Roll, Insta-Load™	10
Installing Ink Cartridges.....	9

K

Keypad Controls	
How to Use.....	26
Keypad Controls/Indicator Light Descriptions.....	29

L

LED indicator	
cartridge left	30

cartridge right.....	30
Line Feed Button	27

M

Media specifications	
ink cartridge	22
Media Specifications	22
Most Frequently Asked Questions.....	44

N

New Cartridge Button	27
New Cartridge Button/Self-Test	29

O

Operating the Keypad	26
Optional Printer Configurations	14
Optional Printer Features.....	13
Options	33

P

Paper Low	
Adjusting.....	7
Paper Low Adjustment Requirements	8
Paper Roll and Paper Core Diameters	23
Pin Assignments	
Cash Drawer Connector	6
Pitch.....	20
Placing the Printer In Configuration Mode.....	37
Print Characteristics.....	20
printer	
dimensions	15
Printer	
Color ready Option	33
Printer Features.....	13
Printer Optional Features	13
Printer Specifications.....	13
Printing Specifications.....	17
Product Information.....	i
Disclaimer.....	i
Drivers and Utilities Available.....	iii
Internet Sales Service.....	iii
Internet Support	iii
Product Support	ii
Programmer's Guide.....	iii
Regulatory Compliance.....	i
Return Policies.....	ii
Service Information	ii
Shipping Printers	ii
Warranty Information	ii

R

Receipt Printing.....	23
Remote Power Down	29

S

Self Test Hints and Suggestions	36
Self-Test Mode	36
Using	36
Setting Configuration	11
Setting Paper Low	7
Setup Instructions.....	1
Specifications	
Dimensions.....	15
Environmental Conditions.....	21
Interface	15
Paper Roll Diameter	23
Power Requirements.....	16
Printer	15
Relative Humidity	21
Reliability	16
Standard Printer Features	13
Standby Button.....	27
Supplies	
Ink Cartridges.....	43
Ordering	43
Ordering Cables.....	43
Ordering Paper	43
Supported Emulations	14

T

Testing the Printer	36
Trademarks.....	i
TransAct Information	
How to Contact Technical Support	iv
TransAct Technologies, Contacting Ithaca Facility.....	iv
Troubleshooting	
Common Setup Problems	12
Correcting Common Operational Problems	41
Keypad Indicator Quick Reference Chart.....	40

U

Unpacking the Printer	2
Using Ink Cartridges	34
Using the New Cartridge Button	27

W

What is covered in this Operator's Guide	v
Where Can You Find More Information	iii

